



nuova

SIMONELLI®

espresso coffee machines



AURELIA II

LIBRETTO ISTRUZIONI
USER HANDBOOK MANUEL D'INSTRUCTIONS

DICHIARAZIONE DI CONFORMITÀ CE
CE DECLARATION OF CONFORMITY



nuova simonelli

espresso coffee machines

Via M. D'Artegiani, 6 - 62031 Bellante del Chienti (MC)

(I) declare, under my responsibility, that the product:
declares under my responsibility that the product:

MACCHINE PER CAFFÈ ESPRESSO
MODELLI: Aurelia II - versioni S, V, DIGIT, T3

ESPRESSO COFFEE MACHINES
MODELS: Aurelia II - versions S, V, DIGIT, T3

of which this declaration relates, following the provisions of the Directives:
to which this declaration relates, following the provisions of the Directives:

EN 60335-2-75:2004 + A1:2005 + A11:2006
in combination with
EN 60335-1:2002 + A1:2004 + A11:2004 + A12:2006 + A2:2006
EN 50366:2003 + A1:2006

and is conforme alle direttive:
following the provisions of the Directives:

2006 / 95 / CE Low Voltage
2004 / 108 / CE (EMC)

data: **Marzo 2012**
March 2012

nuova simonelli s.r.l.
CA Amministratore Delegato
(Official Name)

Congratulations,

By purchasing the AURELIA II you have made an excellent choice.

The purchase of a professional espresso coffee-maker involves various elements of selection: the name of the manufacturing firm, the machine's specific functions, its technical reliability, the option of immediate and suitable servicing, its price. You certainly evaluated all these factors and then made your choice: the AURELIA II model.

We think you have made the best choice and after every coffee and cappuccino you will be able to assess this.

You will see how practical, convenient and efficient working with con AURELIA II is.

If this is the first time you have bought a **Nuova Simonelli** coffee machine, welcome to high quality coffee-making; if you are already a customer of ours, we feel flattered by the trust you have shown us.

Thanks of the preference.

With best wishes,

Nuova Simonelli s.r.l.



AURELIA II

TECHNICAL CHARACTERISTICS

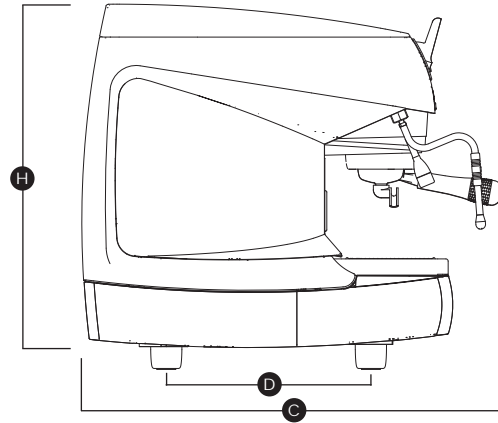
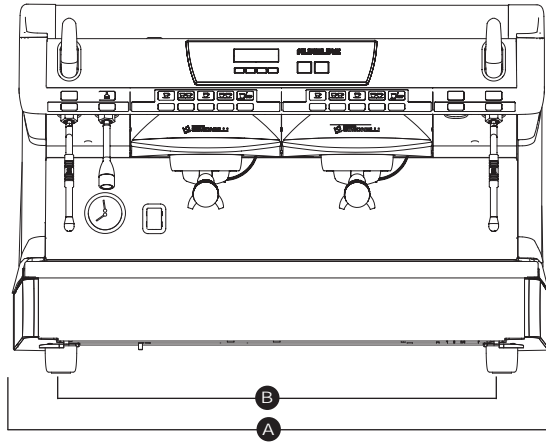

	2 Groups		3 Groups		4 Groups	
NET WEIGHT	74 kg	164 lb	88 kg	194 lb	102 kg	225 lb
NET WEIGHT *	76 kg	168 lb	90 kg	198 lb	-	-
GROS WEIGHT	80 kg	176 lb	100 kg	220 lb	115 kg	254 lb
GROS WEIGHT *	82 kg	181 lb	102 kg	225 lb	-	-
POWER	4500 W	4500 W	5000 W	5000 W	5000 W	5000 W
POWER *	7300 W	7300 W	9100 W	9100 W	-	-
DIMENSIONS	Ⓐ 815 mm	Ⓐ 32 11/16"	Ⓐ 1045mm	Ⓐ 41 11/8"	Ⓐ 1275 mm	Ⓐ 50 31/16"
	Ⓑ 720 mm	Ⓑ 28 5/16"	Ⓑ 950 mm	Ⓑ 37 3/8"	Ⓑ 1180 mm	Ⓑ 46 7/16"
	Ⓒ 565 mm	Ⓒ 22 31/16"	Ⓒ 565 mm	Ⓒ 22 31/16"	Ⓒ 565 mm	Ⓒ 22 31/16"
	Ⓓ 370 mm	Ⓓ 14 9/16"	Ⓓ 370 mm	Ⓓ 14 9/16"	Ⓓ 370 mm	Ⓓ 14 9/16"
	Ⓗ 565 mm	Ⓗ 22 3/16"	Ⓗ 565 mm	Ⓗ 22 3/16"	Ⓗ 565 mm	Ⓗ 22 3/16"

* For version T3 only

AURELIA II

INDEX

	TECHNICAL CHARACTERISTICS	42
1.	DESCRIPTION	
	AURELIA S - V - DIGIT - T3	45
1.1	ACCESSORIES LIST	46
2.	SAFETY PRESCRIPTION	47
3.	TRANSPORT AND HANDLING	50
3.1	MACHINE IDENTIFICATION	50
3.2	TRANSPORT	50
3.3	HANDLING	50
4.	INSTALLATION AND PRELIMINARY OPERATIONS	50
5.	ADJUSTMENTS TO BE MADE BY A QUALIFIED TECHNICIAN ONLY	52
5.1	FILLING BOILER MANUALLY	52
5.2	PRESSURE SWITCH (version S and V) / PUMP (version S, V, Digit and T3) ADJUSTMENT	52
5.3	HOT WATER ECONOMISER ADJUSTMENT	53
5.4	CLOCK BATTERY REPLACEMENT (Digit and T3 version only)	53
5.5	PUSH-BUTTON PANEL REPLACEMENT	53
6.	USE	54
6.1	COMMISSIONING PROCEDURE OR AFTER BOILER MAINTENANCE (T3 VERSION)	54
6.2	TURNING THE MACHINE ON	54
6.2.1	AURELIA T3 and Digit	54
6.2.2	AURELIA V - S	55
6.2.3	AURELIA DIGIT - V - S WITH LED SYSTEM (OPTIONAL)	55
6.3	MAKING COFFEE	56
6.4	USING STEAM	56
6.5	MAKING CAPPUCINO	56
6.6	HOT WATER SELECTION	57
6.7	TIMED STEAM NOZZLE	57

7.	PROGRAMMING AURELIA T3 and DIGIT	58
7.1	KEY	58
7.2	PROGRAMMING (USER Mode)	58
7.3	PROGRAMMING (TECHNICIAN MODE)	59
7.4	PROGRAMMING AURELIA V	68
7.5	PROGRAMMING AURELIA S	71
8.	CLEANING	73
8.1	SWITCHING OFF THE MACHINE	73
8.2	CLEANING THE OUTSIDE OF THE MACHINE	73
8.3	CLEANING THE STAINLESS COFFEE-HOLDERS	73
8.4	CLEANING THE UNIT WITH THE AID OF THE BLIND FILTER	73
8.5	CLEANING FILTERS AND FILTER-HOLDERS	73
9.	MAINTENANCE	74
9.1	RESIN AND SOFTENER REGENERATION	74
10.	Aurelia Digit MACHINE FUNCTION MESSAGES	75
11.	Aurelia V MACHINE FUNCTION MESSAGES	77
12.	Aurelia S MACHINE FUNCTION MESSAGES	78

AURELIA II

1. DESCRIPTION AURELIA II S - V - DIGIT - T3

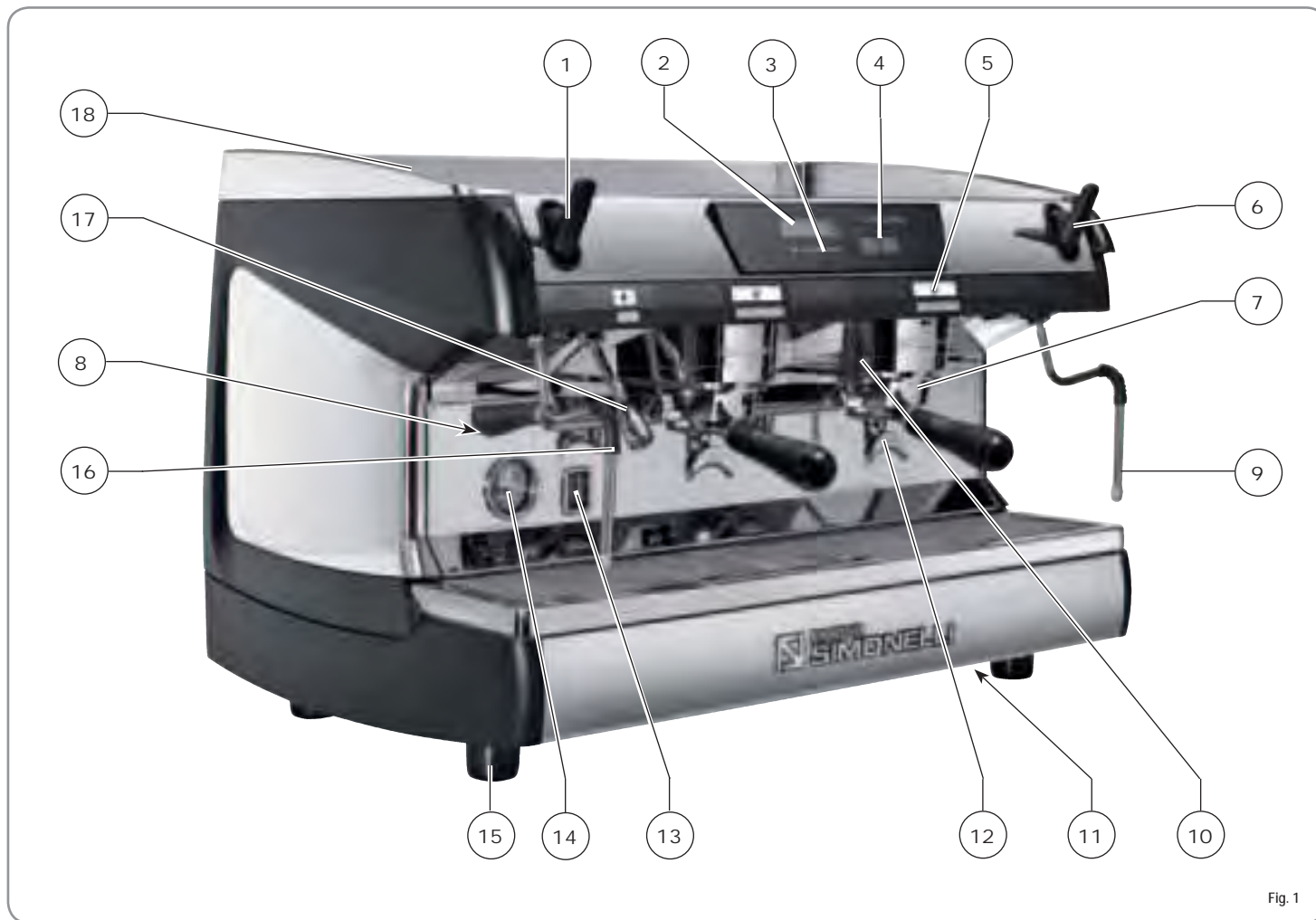

ENGLISH

Fig. 1

KEY

- | | | |
|--|--|--|
| <ul style="list-style-type: none"> 1 Steam knob 2 LCD Display 3 Functions buttons 4 Selections buttons 5 Delivery unit buttons 6 Steam knob 7 Filter-holder 8 Data plate | <ul style="list-style-type: none"> 9 Manual steam nozzle 10 Delivery unit 11 Main switch 12 2 coffees spout 13 Optical level 14 Pressure Gauge 15 Adjustable foot 16 Manual steam nozzle | <ul style="list-style-type: none"> 17 Hot water nozzle 18 Electric cup-warmer
(steam cup-warmer, optional) |
|--|--|--|

1.1 ACCESSORIES LIST

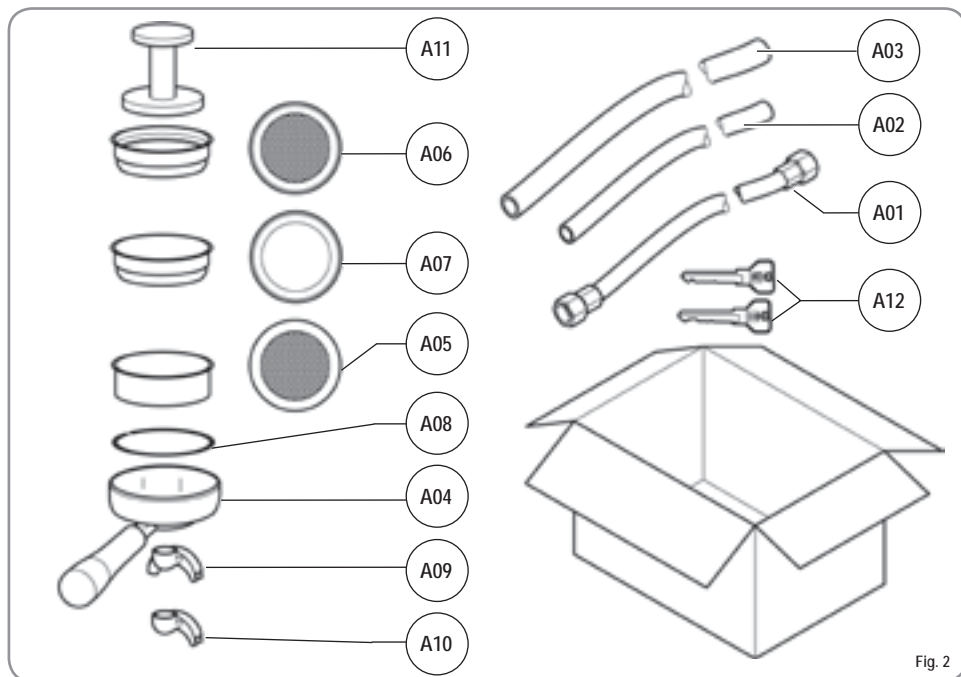

Fig. 2

CODE	DESCRIPTION	2 GROUPS	3 GROUPS	4 GROUPS
A01	Filling tube 3/8"	1	1	1
A02	Unit tub draining tube Ø 20 mm - l. 150 cm	1	1	1
A03	Worktop draining tube Ø 25 mm - l. 150 cm	1	1	1
A04	Filter-holder	3	4	5
A05	Double filter	2	3	4
A06	Single filter	1	1	1
A07	Blind filter	1	1	1
A08	Spring	3	4	5
A09	Double delivery spout	2	3	4
A10	Single delivery spout	1	1	1
A11	Coffee presser	1	1	1

2. SAFETY PRESCRIPTION

This book is an integral and essential part of the product and must be given to the user.

Read this book carefully. It provides important information concerning safety of installation, use and maintenance.

Save it carefully for future reference.

After unpacking, make sure the appliance is complete.

In case of doubts, do not use the appliance, but consult a qualified technician.

Packaging items which are potentially dangerous (plastic bags, polystyrene foam, nails, etc.) must be kept out of children's reach and must not be disposed of in the environment.

DANGER OF POLLUTION

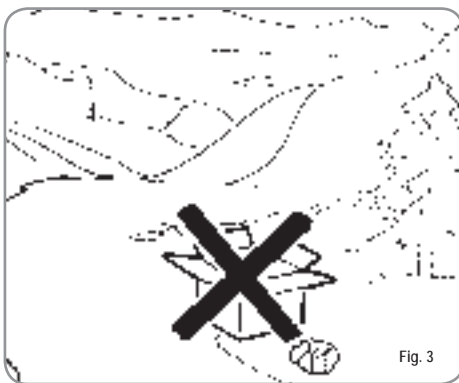

Fig. 3

Before connecting the appliance make sure the rating plate data correspond with the mains.

This plate is on the front panel at the top right hand side of the appliance. The appliance must be installed by qualified technicians in accordance with current standards and manufacturer's instructions.

The manufacturer is not liable for any damage caused due to failure to ground the system.

For the electrical safety of the appliance, it is necessary to equip the system with the proper grounding. This must be carried out by a qualified electrician who must ensure that the electric power of the system is sufficient to absorb the maximum power input stated on the plate.



Fig. 4

In particular you must ensure that the size of the wiring cables is sufficient to absorb power input.

The use of adapters, multiple sockets or extensions is strictly forbidden. If they prove necessary, call a fully qualified electrician.

For appliances powered at 220-230 V, the maximum impedance from the mains must be no higher than 0.37 Ohm.

When installing the device, it is necessary to use the parts and materials supplied with the device itself. Should it be necessary to use other parts, the installation engineer needs to check their suitability for use in contact with water for human consumption.

The machine must be installed in compliance with the local health standards in force for plumbing systems.

Therefore, contact an authorized plumber.

The device needs to be supplied with water that is suitable for human consumption and compliant with the regulations in force in the place of installation. The installation engineer needs confirmation from the owner/manager of the system that the water complies with the requirements and standards stated above.

This appliance must only be used as described in this handbook. The manufacturer shall not be liable for any damage caused due to improper, incorrect and unreasonable use.

This appliance is not suitable for use by children or persons with reduced physical, sensory or mental capabilities, or by persons with a lack of experience or knowledge, unless supervised or given instructions.

 The maximum and minimum storage temperatures must fall within a range of [-5, +50]°C.

 The operating temperature must be within the range of [+5, +35]°C.

 At the end of installation, the device is switched on and taken to rated operating conditions, leaving it in a state in which it is "ready for operation".

The device is then switched off and the whole hydraulic circuit is bled of the first lot of water in order to remove any initial impurities.

The device is then refilled and taken to rated operating conditions.

After reaching the "ready for operation" condition, the following dispensing operations are carried out:

- 100% of the coffee circuit through the coffee dispenser (for more than one dispenser, this is divided equally);
- 100% of the hot water circuit through the water dispenser (for more than one dispenser, this is divided equally);
- opening of each steam outlet for 1 minute.

At the end of installation, it is good practice to draw up a report of the operations.

 Basic rules must be observed when using any electric appliance.

In particular:

- do not touch the appliance when hands or feet are wet;
- do not use the appliance when barefoot;

- do not use the appliance when barefoot;
- do not pull the supply cord out of the socket to disconnect it from the mains;
- do not leave the appliance exposed to atmospheric agents (rain, sun, etc.);
- do not let the appliance be used by children, unauthorised staff or staff who have not read and fully understood the contents of this handbook.

 During installation, the mains power system needs to be equipped with a disconnecter switch to cut off each phase.

 Before performing any maintenance operations, the authorised service engineer must switch off the machine and open the phase disconnecter.

 For all cleaning operations comply exclusively with the instructions given in this booklet.

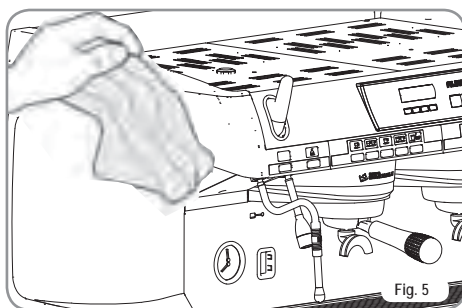



 If the appliance breaks down or fails to work properly, switch it off. Any intervention is strictly forbidden.

Repairs should only be made by the manufacturer or authorized service centres.

Only original spare parts must be used.

Failure to observe the above, could make the appliance unsafe.

 For installation, the qualified electrician must fit an omnipolar switch in accordance with the safety regulations in force and with 3 (0,12) or more mm (in) between contacts.

 To avoid dangerous overheating, make sure the supply cord is fully uncoiled.

 Do not obstruct the extraction and/or dissipator grids, especially of the cup warmer.

 The user must not replace the appliance supply cord. If the cord is damaged, switch off the appliance and have a qualified technician change the cord.

 Single-phase appliances with current above 15 A and three-phase appliances sold without plugs are directly wired to the mains power and therefore, it is not possible to use a plug.



CAUTION
RISK OF ELECTRIC SHOCK

 If no longer using the appliance, we recommend making it inoperative; after removing the plug from the mains electricity, cut the power supply cable.

 **CAUTION**
RISK OF POLLUTION

 Non disperdere la macchina nell'ambiente: per lo smaltimento rivolgersi ad un centro autorizzato o contattare il costruttore che darà indicazioni in merito.



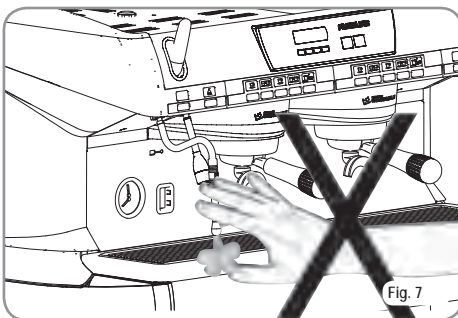

 **CAUTION**
RISK OF INTOXICATION

 Use the steam nozzle with care and never place hands below the jet of steam. Do not touch the nozzle immediately after use.



 **CAUTION**
RISK OF BURNS OR SCALDING

 We remind you that before carrying out any installation, maintenance, unloading or adjustment operations, the qualified operator must put on work gloves and protective footwear.

 The maximum noise disturbance level is lower than 70db.

 If the pipe connecting to the mains water is replaced the old pipe must never be re-used.

 **CAUTION**



INFORMATION TO THE USERS
Under the senses of art. 13 of Law Decree 25th July 2005, n. 151 "Implementation of the Directives/ Guidelines 2002/95/CE, 2002/96/CE and 2003/108/CE, concerning the reduction of the use of dangerous substances in electric and electronic equipment, as well as the disposal of wastes".

The symbol of the crossed large rubbish container that is present on the machine points out that the product at the end of its life cycle must be collected separately from the other wastes. The user for this reason will have to give the equipment that got to its life cycle to the suitable separate waste collection centres of electronic and electrotechnical wastes, or to give it back to the seller or dealer when buying a new equipment of equivalent type, in terms of one to one. The suitable separate waste collection for the following sending of the disused equipment to recycling, the dealing or handling and compatible environment disposal contributes to avoid possible negative effects on the environment and on the people's health and helps the recycling of the materials the machine is composed of. The user's illegal disposal of the product implies the application of administrative fines as stated in Law Decree n.22/1997" (article 50 and followings of the Law Decree n.22/1997).

3. TRANSPORT AND HANDLING

3.1 MACHINE IDENTIFICATION

Always quote the machine serial number in all communications to the manufacturer, Nuova Simonelli.

S.N.	DATE	
<input type="checkbox"/> AURELIA II	<input type="checkbox"/> S	<input type="checkbox"/> V
<input type="checkbox"/>	<input type="checkbox"/> DIGIT	<input type="checkbox"/> 110-120 V~
	<input type="checkbox"/> T 3	<input type="checkbox"/> 208-240 V~
GR. <input type="checkbox"/> 1 <input type="checkbox"/> 2 <input type="checkbox"/> 3 <input type="checkbox"/> 4	<input type="checkbox"/> 50	<input type="checkbox"/> 60 Hz
	<input type="checkbox"/>	<input type="checkbox"/> 380-400 V 3N~
MAX PRESSURE 0.18MPa	MAX OPERATING PRESSURE 0.165MPa	
MAX INLET PRESSURE 0.65MPa		
<input type="checkbox"/> 4500 W	<input type="checkbox"/> 5200 W	<input type="checkbox"/> 6000 W
<input type="checkbox"/> 7300 W	<input type="checkbox"/> 9100 W	<input type="checkbox"/>
BELFORTE DEL CHIANTI (MC) MADE IN ITALY		
31000420 rev1	Fig. 8	

3.2 TRANSPORT

The machine is transported on pallets which also contain other machines - all boxed and secured to the pallet with supports.

Prior to carrying out any transport or handling operation, the operator must:

- put on work gloves and protective footwear, as well as a set of overalls which must be elasticated at the wrists and ankles.
- The pallet must be transported using a suitable means for lifting (e.g., forklift).

3.3 HANDLING

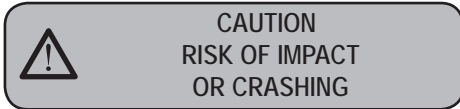

During all handling operations, the operator must ensure that there are no persons, objects or property in the handling area. The pallet must be slowly raised to a height of 30 cm (11,8 in) and moved to the loading area. After first ensuring that there are no persons, objects or property, loading operations can be carried out.

Upon arrival at the destination and after ensuring that there are no persons, objects or property in the unloading area, the proper lifting equipment (e.g. forklift) should be used to lower the pallet to the ground and then to move it (at approx. 30 cm (11,8 in) from ground level), to the storage area.

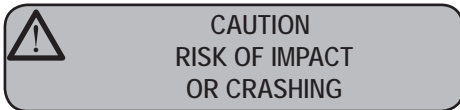

Before carrying out the following operation, the load must be checked to ensure that it is in the correct position and that, when the supports are cut, it will not fall.

The operator, who must first put on work gloves and protective footwear, will proceed to cut the supports and to storing the product. To carry out this operation, the technical characteristics of the product must be consulted in order to know the weight of the machine and to store it accordingly.

4. INSTALLATION AND PRELIMINARY OPERATIONS

After unpacking, assess that the machine and its accessories unit are complete, then proceed as follows:

- place the machine so that it is level on a flat surface;
- assemble its supporting feet by inserting the insert into the cylindrical unit;
- twist the rubber foot into the screw thread inside the unit;
- screw the whole assembled unit into the allotted setting for the machine's adjustable feet;
- level the machine by regulating the adjustable feet;

NOTE: the unit grooves have to face upwards, as shown in the following illustration.

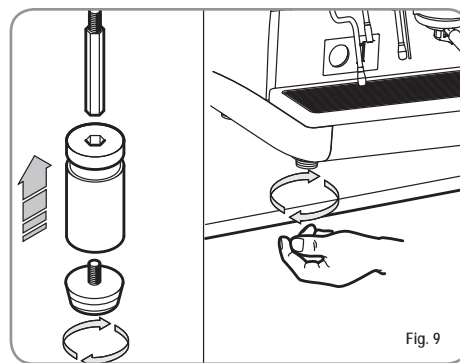

It is advisable to install a softener (1) and then a mesh filter (2) on the external part of the plumbing system, during preliminaries and after levelling the machine.

In this way impurities like sand, particles of calcium, rust etc will not damage the delicate graphite surfaces and durability will be guaranteed.

Following these operations, connect the plumbing systems as illustrated in the following figure.



WARNING

Recommended mains pressure for the water is [2.3] bar.

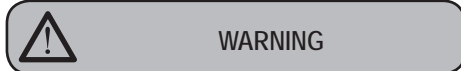

WARNING

Avoid throttling in the connecting tubes. Assess that the drain pipe (3) is able to eliminate waste.

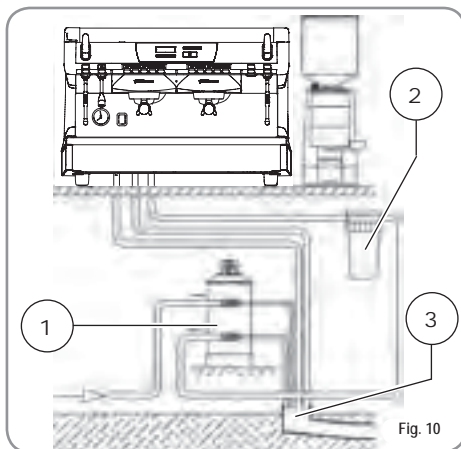

KEY

- 1 Softener
- 2 Mesh filter
- 3 Drain Ø 50 mm

NOTE: For a correct functioning of the machine the water works pressure must not exceed 4 bars.

Otherwise install a pressure reducer upstream of the softener; the internal diameter of water entrance tube must not be less than 6mm.

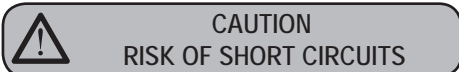

CAUTION
RISK OF SHORT CIRCUITS

The machine must always be protected by an automatic omnipolar switch of suitable power with contact openings of equal distance or more than 3mm.

Nuova Simonelli is not liable for any damage to people or objects due to not observing current security measures.

Prior to connecting the machine to the electrical mains, assess that the voltage shown on the machine's data plate corresponds with that of the mains.

If it does not, carry out the connections on the basis of the available electrical line, as follows:

- for V 380 / 3 phases voltage + Neutral:

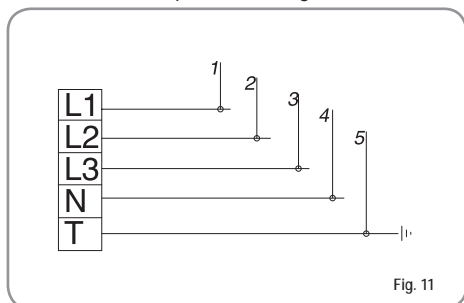

- for V 230 / monophase voltage

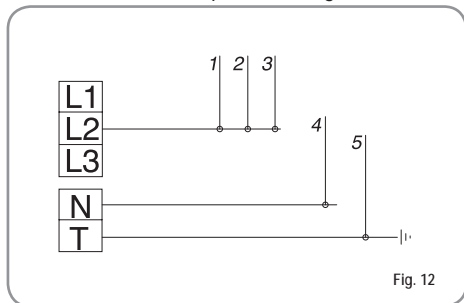

KEY

- | | |
|---------|----------------|
| 1 Black | 4 Blue |
| 2 Grey | 5 Yellow-green |
| 3 Brown | |

NOTE: At the start of the day's activities and in any case, if there are any pauses of more than 8 hours, then it is necessary to change 100% of the water in the circuits, using the relevant dispensers.

NOTE: In case of use where service is continuous, make the above changes at least once a week.

5. ADJUSTMENTS TO BE MADE BY A QUALIFIED TECHNICIAN ONLY

5.1 FILLING BOILER MANUALLY

NOTE: this operation must be carried out with the machine turned off.

All models **AURELIA II** are equipped with a level gauge to keep the water level inside the boiler constant. When using the machine for the first time, it is advisable to fill the boiler by hand to avoid damaging the electrical resistor and turning on the electronic protection.

If this should happen, just turn the machine off and then start it up again to complete its loading procedure (see chapter "MACHINE FUNCTIONS MESSAGE – LEVEL ERROR").

To fill the boiler manually for the first time, proceed as follows:

- remove the worktop grid;
- turn the manual "A" level tap so that water will enter the boiler;
- once the maximum level has been reached, as indicated by the optical level, turn tap "A" off;

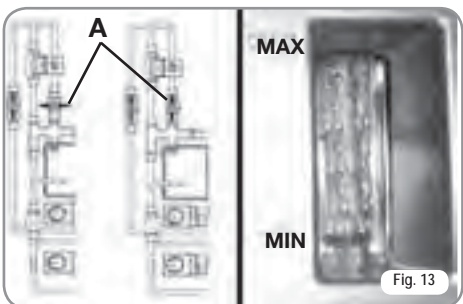

- switch the machine on by placing the general switch on "I"; this will activate the level gauge which will automatically maintain the water level inside the boiler.

5.2 PRESSURE SWITCH (version S and V) / PUMP (version S, V, Digit and T3) ADJUSTMENT

NOTE: this operation can be carried out while the machine is turned on.

To adjust the service pressure of the boiler, thus regulating the water temperature, according to the various functions and needs of the coffee desired, proceed as follows:

- remove the worktop grid cover;
- remove the plastic protection, unscrewing the two side screws (A), as shown in the following figure;

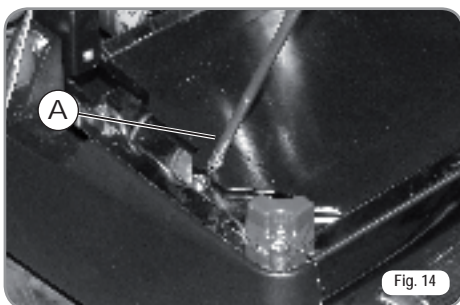

- use the pressure switch adjustment screw to INCREASE (anticlockwise) or REDUCE (clockwise) the pressure;

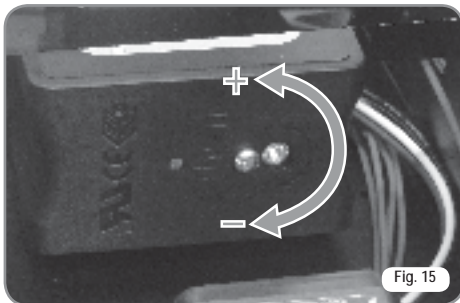

Advisable pressure: 1 - 1,4 bar (according to the kind of coffee).

Pressure can be adjusted directly from the programming function on the Digit and T3 versions.

- To adjust pump pressure, use the adjustment dial of the pump to INCREASE (clockwise) or REDUCE (anticlockwise) the pressure;



Advisable pressure: 9 bar.

- The set pump pressure is shown on the lower part of the gauge.

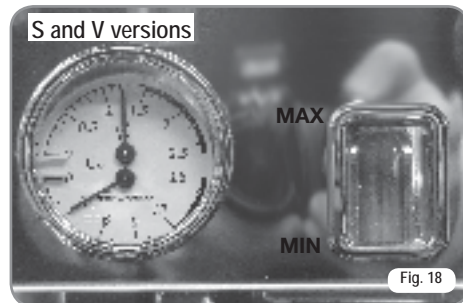
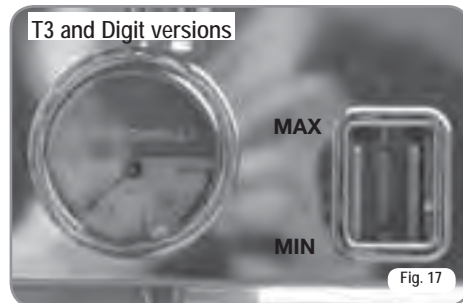

At the end of the adjustments, refit the plastic protection in its housing and fasten it into place with the two side screws before refitting the work surface grille.

5.3 HOT WATER ECONOMISER ADJUSTMENT

NOTE: this operation can be carried out while the machine is turned on.

All models **AURELIA II** are equipped with a hot water mixer tap which adjusts the water temperature and optimises the system's performance.

To adjust the hot water economiser, use a screwdriver to turn the screw inside the cup warmer as illustrated in the figure.

- Turn it **CLOCKWISE / ANTICLOCKWISE** to **REDUCE / INCREASE** the temperature of the hot water;

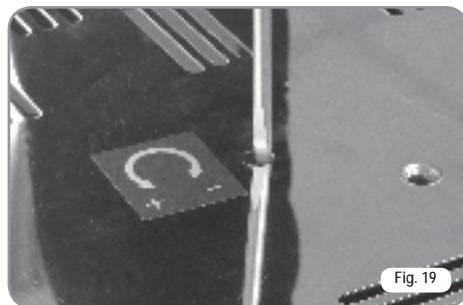

5.4 CLOCK BATTERY REPLACEMENT (Digit and T3 version only)

The electronic control unit on the Digit and T3 version has a lithium battery to power the clock and this has a life of around three years, after which it may be necessary to replace it.

In case the machine has remained unutilised for a long time, the clock can be blocked by proceeding as follows:

- with the machine off the display will read:

OFF

- press the **ENTER** key for 5 seconds; the display will read:

STOP CLOCK

The clock will start up again as soon as the machine is plugged in once more.

 **WARNING**

Replacement of the lithium battery must be carried out **EXCLUSIVELY** by Qualified Technician.

Nuova Simonelli cannot be held liable for any damage to people or things due to non observance of the safety prescriptions described in this booklet.

5.5 PUSH-BUTTON PANEL REPLACEMENT

For correct functioning of the machine, personalising each button panel card at time of replacement is necessary; proceed as follows on the selectors placed on the card (on the key side).

GROUP	sw1	sw2	sw3	sw4	sw5	sw6	sw7	sw8
Group 1	On	Off	Off	Off	On	Off	Off	Off
Group 2	Off	On	Off	Off	Off	On	Off	Off
Group 3	Off	Off	On	Off	Off	Off	On	Off
Group 4	Off	Off	Off	On	Off	Off	On	Off

6. USE

Before starting to use the appliance, the operator must be sure to have read and understood the safety prescriptions contained in this booklet.

6.1 COMMISSIONING PROCEDURE OR AFTER BOILER MAINTENANCE (T3 VERSION)

When commissioning the machine for the first time or after carrying maintenance switch ON the machine using the main switch positioned lower down and on the right and proceed as follows:

- 1) If the message "OFF - CLOCK DISENABLED" appears on the display proceed as follows in step three.
- 2) If the message "OFF" appears on the display press the **ENTER** key until the message "OFF - CLOCK DISENABLED" appears on the display and then proceed as follows in step three.
- 3) Switch ON the machine by pressing the **RESET** key and automatically water will exit from the units for 45 seconds to ensure that the coffee boiler has been correctly filled.
This cycle cannot and must not be interrupted.
If this cycle is interrupted due to an electricity failure or accidental switching off of the machine using the main switch, when the machine is switched on again the cycle will start again for another 45 seconds.

6.2 TURNING THE MACHINE ON

6.2.1 AURELIA T3 and Digit

SWITCH ON: plug the machine into the power socket and press the switch "A" so it is in position "I"; the machine will switch on. Pressing the switches "B" and "C" so that they are in position "I" will switch on the LEDs even when the machine is switched off.

NOTE: LEDs are installed as standard on the T3 version and Optional on the Digit version.

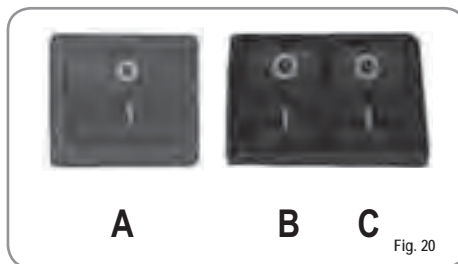

WARNING

In case the auto diagnosis indicates error or malfunction, call an assistance centre; the operator **MUST NOT** intervene.

- The display, which is not illuminated, will read:

OFF

NOTE: The machine is not operational, since the main switch only powers the electronic card.



WARNING

For electronic card maintenance, turn the machine off by means of the external main switch or disconnect the plug.

MANUAL SWITCHING ON/OFF

Automatic On/Off NOT PROGRAMMED

NOTE: make sure that the general switch is always on the position "I".

The state of the machine will be shown

by the signal:

SWITCH ON: press the **RESET** key for 2 seconds, the buzzer will beep, the display will light up to indicate the release of the EPROM for about 1 second. The control unit will start up an auto diagnosis cycle to check the functions, all the selection keys will light up. Once the check is completed the display will read:

HEATING

with the day and time. When 110°C has been reached, the heating message will disappear and will be replaced by the words:

MACHINE READY

NOTE: on completion of the check up all the selection keys are activated.



WARNING

In case the auto diagnosis indicates error or malfunction, call an assistance centre; the operator **MUST NOT** intervene.

POWER OFF: press the  key for 2 seconds; the machine will turn off and the display will read:

OFF

Automatic On/Off PROGRAMMED

NOTE: make sure that the general switch is always on the position "I".

The state of the machine will be shown by the signal: 

The machine will SWITCH ON at the first programmed switch-on time (see the section entitled PROGRAMMING at the paragraph PROGRAMMING ON - OFF).

The control unit will perform an auto diagnosis of all functions and all of the selection keys will light up. Once the diagnosis is complete, the display will read as follows:

HEATING

with the date and time. Once the temperature of 110°C has been the word "Heating" will disappear to be replaced by:

MACHINE READY

NOTE: once the auto diagnosis has been completed all the keys are activated.

 **WARNING**

In case the auto diagnosis indicates error or malfunction, call the assistance centre; the operator **MUST NOT** intervene.

The machine will SWITCH OFF at the first time set for stopping the coffee maker (see chapter on PROGRAMMING and paragraph on PROGRAMMING ON - OFF).

NOTE: the machine can be switched on or off manually as indicated in the previous paragraph.

6.2.2 AURELIA V - S

SWITCH ON: plug the machine in and position the main switch on "I". The state of the machine will be shown by the signal: 



 **WARNING**

In case the auto diagnosis indicates error or malfunction, call the assistance centre; the operator **MUST NOT** intervene.

SWITCH OFF: press the main switch into the "O" position to switch the machine and the signal off.

6.2.3 AURELIA DIGIT - V - S WITH LED SYSTEM (OPTIONAL)

SWITCH ON: plug the machine into the power socket and press the switch "A" so it is in position "I"; the machine will switch on. Pressing the switches "B" and "C" so that they are in position "I" will switch on the LEDs even when the machine is switched off.

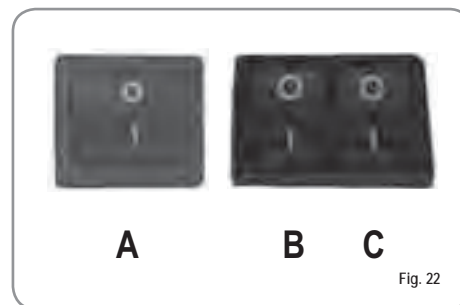

 **WARNING**

In case the auto diagnosis indicates error or malfunction, call the assistance centre; the operator **MUST NOT** intervene.

6.3 MAKING COFFEE

Unhitch the filter-holder and fill it with one or two doses of ground coffee depending on the filter used.



Fig. 23

Press the coffee with the provided coffee presser, dust off any coffee residue from the rim of the filter (this way the rubber gasket will last longer).

Insert the filter in its unit.
Press the desired coffee button:



1 small coffee



2 small coffees



1 long coffee



2 long coffees

By starting up the coffee brewing procedure the unit's pump is activated and the unit's solenoid valve is opened.

By pressing it, the button will turn on and signal the operation.

NOTE: when in pause, leave the filter-holder inserted in the unit so that it will keep warm.

To guarantee the utmost thermic stability during use, the delivery units are thermo-compensated with complete hot water circulation.

6.4 USING STEAM



CAUTION
RISK OF BURNS OR SCALDING

While using the steam nozzle, you must pay attention to not place your hands beneath it or touch just after it has been used.

To use steam just pull or push the provided lever (Fig. 24).

By pulling it completely the lever will hold a position of maximum delivery; by pushing it, the lever will automatically give way.

The two steam nozzles are articulated to guarantee their easy use.

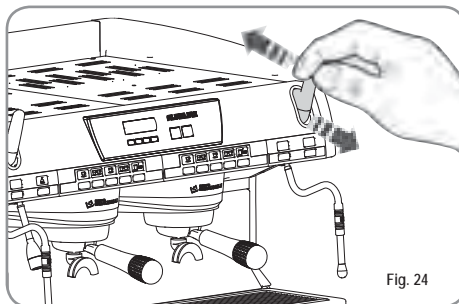

Fig. 24

NOTE: Before using the steam wand, always bleed out any condensation for at least 2 seconds or according to the manufacturer's instructions.

6.5 MAKING CAPPUCCINO

To obtain the typical cappuccino foam, immerse the nozzle all the way into a container 1/3 full of milk (preferably cone-shaped). Turn on the steam. Before the milk starts to boil, pull the nozzle slightly up and lightly move it vertically across the surface of the milk. When you have completed the procedure, clean the nozzle carefully with a soft cloth.

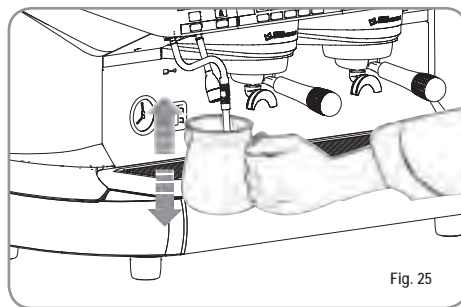

Fig. 25

6.6 HOT WATER SELECTION



While using the hot water nozzle, pay careful attention not to place your hands beneath it or touch it just after it has been used.

This nozzle delivers hot water to make tea or herb teas.

Place a suitable container under the hot water nozzle.

Press the hot water selection button once



Make sure the button lights up.

Water will be delivered from the hot water nozzle for as long as the set time indicates.

NOTE: Hot water can be delivered at the same time as coffee.

6.7 TIMED STEAM NOZZLE

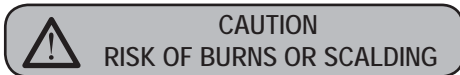

While steam is being delivered do not touch the nozzle with any part of the body, and have it always facing downwards towards the cup-holder grid.

It provides steam ejection to foam milk or to heat up other liquids.

Place a suitable container under the automatic steam nozzle.

Press the steam selection button once



Make sure that the button lights up.

Steam will be ejected from the automatic steam nozzle.

Press it again to arrest delivery.

As an optional on Digit and V models, it is possible to fit a wand with temperature probe, which stays open until the drink to be heated reaches the set temperature.

7. AURELIA T3 and DIGIT PROGRAMMING

7.1 KEY

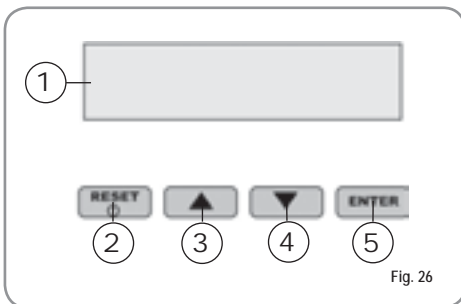

- 1 LCD Display.
- 2 RESET key to turn the machine on and off and to exit menu.
- 3 CURSOR key: to scroll the menu and to increase and decrease values.
- 4
- 5 ENTER key: to access the menu.

LIST OF DISPLAY FUNCTIONS (USER Mode)

AUTO CLEAN CYCLE
DOSES
POURING COUNT
TOTAL
MACHINE TOTAL
TOTAL WASHES

7.2 PROGRAMMING (USER Mode)

To enter the user mode programming environment, press and hold down the washing key for 8 seconds and wait to hear the first acoustic signal.

The machine will read:

AUTO.CLEAN.CYCLE

AUTOMATIC CLEANING CYCLE

- The display will show:

AUTO.CLEAN.CYCLE

- Press and the display will read:

AUTO.CLEAN.CYCLE
SELECT

- the central key of each unit 1 long coffee, will begin to flash on and off. Insert the blind filter (fig. 2 A07) into the filter-holder, add half a dose of PULICAFF and attach the filter-holder into the unit where you intend to carry out the automatic cleaning cycle. Carrying out a cleaning cycle in more than one unit at a time is possible.

- Press the 1 long coffee key to start the unit automatic cleaning cycle. The display will read

AUTO.CLEAN.CYCLE
i L

where 1L indicates that the cleaning cycle has been activated within the 1st unit. Once the

cycle of 15 deliveries, each one 5 seconds long, with a 10-second pause between each one has been completed, the 1 long coffee key for the selected group will start to flash on and off again and the display will read.

RINSE

- Press the key to view the next functions or to quit the display mode.

DOSES

- The display will read:

DOSES

- Press the key and all of the dose, hot water and steam keys will start to flash.
- Pressing one of the flashing keys will show the corresponding programmed setting on the display.
- Press the key to return to the previous function.
- Press the key to quit the display mode.

POURING COUNT

- The display will read:





DELIVERY COUNT

- Press the key and all of the dose, hot water and steam keys will start to flash.
- Pressing one of the flashing keys will show the corresponding counter on the display.
- Press the key to return to the previous function.
- Press the key to quit the display mode.

TOTAL

- The display will read:

TOTAL

- The long coffee key  of each group will flash on and off and when pressed, the machine will show the number of coffees delivered with that particular group.
- Press the   keys to view the other functions.
- Press the  key to quit the display mode.

MACHINE TOTAL

- The display will read:





MACHINE TOTAL
DELIVE. XXX

- Press the   keys to view the other functions.
- Press the  key to quit the display mode.



















WASH COUNT

- The display will read:

CLEANING COUNTER

- The long coffee key for each group  will flash and when pressed, the display will show the number of wash cycles carried out for that particular group.
- Press the   keys to view the other functions.
- Press the  key to quit the display mode.

LIST OF PROGRAMMABLE FUNCTIONS (TECHNICIAN Mode)

- AUTO.CLEAN.CYCLE 
- DOSE PROGRAM. 
- DELIVERY COUNT 
- ACTIVE UNITS  *
- ON-OFF PROGRAM. 
- ENERGY SAVING 
- SETPOINT TEMPERATURE (and OFFSET)  *
- CUP-WARMER PRO. 
- DATE/TIME 
- DISPLAY SETTING (and DELIVERING TIME)  *
- DELIVERING IN WASHING MODE 
- POURING TIME  °
- SETPOINT PRESS. 
- HISTORICAL ALARM 
- MAINTENANCE 
- WASH ALARM 
- LANGUAGE 
- TEMPERATURE 
- LIGHT ADJUST 

 Operation to be carried out EXCLUSIVELY by a Qualified Technician.

Adjustment by NON qualified technicians can invalidate the guarantee.

* T3 version only

° Digit version only

7.3 PROGRAMMING (TECHNICIAN MODE)

To enter the Technician Mode programming environment:

- Hold down the  key for at least 10 seconds and wait for the acoustic signal.

The display will read:

AUTO.CLEAN.CYCLE

followed by:

PROGRAM. DOSES

AUTOMATIC CLEANING CYCLE

- The display will read:

AUTO.CLEAN.CYCLE

- Press  and the display will read:

AUTO.CLEAN.CYCLE
SELECT

- The central key of each unit  1 long coffee will begin to flash on and off. Insert the blind filter (fig. 2 A07) into the filter-holder, add half a dose of Pulicaff and hook the filter-holder up to the unit for which you intend to carry out an automatic cleaning cycle. It is possible to wash more than one group at the same time.



- Press the  1 long coffee key to start the automatic cleaning cycle on the unit. The display will read:

AUTO.CLEAN.CYCLE
i L

where 1L indicates the cleaning cycle has been activated. Once the cycle of 15 deliveries of 5 seconds each, with a 10-second pause between each one has been completed, the  1 long coffee key of the

selected unit will begin to flash on and off again and the display will read:

RINSE

- Remove any residues of pulicaff from the blind filter and press the  1 long coffee key to start the rinse cycle for the unit or units which have undergone a cleaning cycle. The letter R will remain fixed in the display, like the  1 long coffee key. Once the rinsing cycle of the selected unit or units has been completed, the display will read.

MACHINE READY

If ACTIVE has been selected in the function "DELIVER WHILE WASHING" (see function), after the groups to be cleaned have been selected, pressing the **ENTER** key will quite the washing mode to use the other, non-selected units to deliver coffee.

When the washing mode is closed to make the units not being washed available to deliver coffee, the washing cycle will be shown in the top or bottom line of the screen, according to the choice made in the "DELIVERING TIME" menu. If the delivering times are deactivated, the washing process will be displayed on the bottom line.

It is not possible to open the setting menu and to switch off the machine, either manually or automatically, during an automatic washing cycle not in the menu (therefore, with delivering enabled).

PROGRAMMING DOSES

On the S version, it is possible to programme just hot water and steam (if necessary).

- The display will read:

PROGRAM. DOSES

- Press **ENTER** and the display will read:





PROGRAM. DOSES
SELECT

All the programmable keys will start to flash on and off.

- Press the coffee key you wish to program; the display will read:

VOLUME C.C:

Followed by the dose amount already set by the manufacturers.

- Vary the dose, by pressing the buttons  .
- By pressing the coffee key you want to program, delivery will be started up (in the meantime all the other keys will turn off).
- Once you have the required dose, press the continuous coffee key  to stop pouring.
- The display will show the new dose amount which can still be changed by means of the keys  .
- Press the **ENTER** key to confirm the programmed dose.
- Press the **RESET** key to cancel programming.
- The programmed coffee key will switch off.

Hot Water

- Press the  button and make sure that it lights up.

The display will read:



PROGRAM. DOSES
SECONDS X.X

The value X.X is the default setting.

Press the   keys to vary the hot water delivery time.

- If a new sampling is desired press the  button again.

Delivery starts. When the desired dose has been reached press the button  again.

- The display will show the new dose value set which can still be changed by pressing the   keys.

- Press the **ENTER** key or go on to a further selection to terminate the operation.

- Press the **RESET** key to cancel programming.

The  button will turn off.

Timed steam

- Press the  button and make sure it lights up.

In those models provided with a temperature probe (optional) the control unit automatically recognizes the presence of the probe and the display will read:

PROGRAM. DOSES
STEA.TEM. °C

followed by the temperature set previously by the manufacturer.

Press the keys to vary the temperature of the beverage you want to heat. When the desired temperature has been reached, the steam delivery will automatically stop.

- In the standard version (without temperature probe), on pressing the the display will read:

PROGRAM. DOSES
STEA.SEC.

followed by the amount already set by the manufacturers.

Press the keys to vary the steam delivery time.

- If a new sampling is desired press the button again.

Delivery starts. When the desired dose has been reached press the button again .

- The display will show the new value set which can still be changed by pressing the .

- Press the key or go on to a further selection to terminate the operation.
- Press the key to cancel programming.

The button will turn off.

TRANSFERRING DOSES

- When the display reads:

PROGRAM DOSES
SELECT

transferring the set dose to other units is possible by pressing the key

The display will read:

DOSES TRANSFER
SELECT GROUPS

at this point, the continuous coffee keys of the second, third and fourth groups will flash as shown in Fig. 27.

- Selecting the continuous key (the key will stop flashing and remain lit) will transfer the values programmed for the first group to the other groups, one at a time.

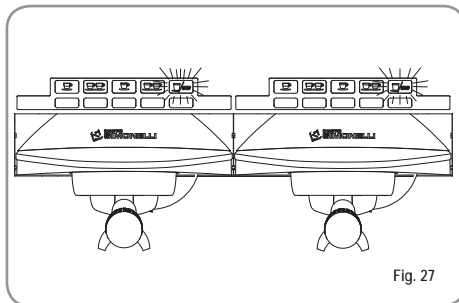

Fig. 27

- Press the key to confirm. At this point the display will read:

PROGRAM DOSES
SELECT

- Press the or the key to exit without confirmation.

STANDARD DOSES

- When the display reads:

DOSES TRANSFER
SELECT GROUPS

we mean to recall the standard dose values.

- Press the key. The display will read:

DEFAULT SETING
SELECT GROUPS

At this point, the continuous coffee keys will begin to flash.

- Select one or more continue keys (the key or keys selected will remain lit up). The key or keys will recall the selected unit's standard doses.
- Press the key to confirm. The display will read:

PROGRAM DOSES
SELECT

- Press the or the key to exit without confirmation.

NOTE: all the selections can be programmed for a maximum of two minutes; after that time a flashing message will appear on the display saying:

ERROR

DELIVERY COUNT

- The display will read:

DELIVERY COUNT

- By pressing the key the display will read:

SELECTION TOTAL
SELECT

- All the delivery keys will start to flash on and off. By pressing one of the delivery keys the amount of the deliveries made will be visualised.
- Hold down the key for 3 seconds to reset.

NOTE: The continuous coffee equals one delivery.

- Press the key and the display will read:

MACHINE TOTAL
DELIVE. XXXX

This indicates the total amount of deliveries made.

- Hold down the key for 3 seconds to reset.
- By pressing the key the display will read:

CLEANING COUNTER

To access the automatic cleaning counter press .

- The long coffee keys on the machine will begin to flash; when the group key is pressed, the display will show the number of wash cycles carried out. Hold down the key for 3 seconds to reset.

ACTIVE UNITS (T3 version only)

- It is possible to set both the units actually present and those to be enabled when the control unit is switched on. To set the number of active units when the machine is switched on and to change the active units, proceed as follows:
 - Switch on the function by pressing the key.
 - It is possible to activate/deactivate individual units by pressing the keys. Press to confirm and to pass on to the next unit. When the last unit is confirmed, the function returns to the main menu.
 - Pressing the key returns to the main menu and any changes made will not be saved.

NOTE: To make a change effective, it is necessary to switch the machine off and then on again, using the main switch located in the bottom right.

NOTE: From the machine ready state, it is possible to activate/deactivate the deactivated/activated units by pressing the key and the button for the unit in question. This temporary change is active until the machine is switched off and then on again from the main switch.

NOTE: If the electronic control unit is replaced, when the "ACTIVE UNITS" are shown on the display, it is necessary to press the long coffee key for the first and second group to make sure that in the "ACTIVE GROUPS X" on the display, X actually corresponds to the number of units installed on the machine.

It is possible to change the value with the keys.

For machines with 2 units, the value should be X=2, for machines with 3 units, the value should be X=3, for machines with 4 units, the value should be X=4.

ON/OFF PROGRAM.

- The display reads:

ON-OFF PROGRAM

- By pressing the display will read:

MONDAY
ON 07:30 OFF 23.30

where the ON and OFF values indicate when the machine will turn on and off.

- Press to change the day forward and backward.
 - Press to vary the programmed starting up time (the message ON 07:30 will start to flash on and off).
 - Use the keys to vary the starting up time.
 - Press to confirm and to go on to the programmed switching off time (the message OFF 23.30 will start to flash on and off).
 - Use the keys to vary the switching off time.
 - Confirm by pressing .
 - To de-activate the on/off function on weekly day-off, press .
- The display will read:

DAY OFF

(to reinstate, press)

After the word SUNDAY, by pressing again, a beep will signal that you have come to the following page.

ENERGY SAVING (stand-by)

- The display will read:

ENERGY SAVING

This function allows the machine to enter an active STANDBY status, where it is possible to choose whether to switch off the machine completely or to keep it at a set pressure (lower than working pressure).

- Press and the display will read:

ENERGY SAVING
XXX

Here it is possible to select the XXX mode using the keys.

The 4 operating modes are:

- OFF: during STANDBY the machine is switched off and the display reads "OFF";
- STANDBY 0.10 bar: during STANDBY, the machine maintains a pressure of 0.10 bar and the display (set to minimum brightness) reads "LOW POWER USE";
- STANDBY 0.50 bar: during STANDBY, the machine maintains a pressure of 0.50 bar and the display (set to minimum brightness) reads "LOW POWER USE";
- STANDBY 0.80 bar: during STANDBY, the machine maintains a pressure of 0.80 bar and the display (set to minimum brightness) reads "LOW POWER USE".

This type of operation is possible when switching the machine on/off manually using the key and when switching the machine on/off automatically using the ON/OFF programming function.

If the RES key is pressed while the machine is in one of the standby conditions (0.10 bar, 0.50 bar, 0.80 bar), the machine switches to OFF. If the key is pressed again, the machine enters the ON mode.

Press the key to confirm the mode selected from the display and go back.

Press the key to go back without confirming.

SETPOINT TEMPERATURE (AND OFFSET) (Version T3 only)

- It is possible to access this function by pressing the key. The key serves to adjust the temperatures of the boilers and units; the key is used to confirm and pass to the next value. When the last unit has been confirmed, the function returns to the main menu.

Pressing the key moves to the next value to be adjusted; any changes made will not be saved.

SETP G1: Unit 1 temperature
SETP C1: Boiler 1 temperature
SETP G2: Unit 2 temperature
SETP C2: Boiler 2 temperature
SETP G3: Unit 3 temperature
SETP C3: Boiler 3 temperature
SETP G4: Unit 4 temperature
SETP C4: Boiler 4 temperature

OFFSET ADJUSTMENT

- When the display reads:

SETPOINT TEMP

- Holding down the one long coffee keys for the first and second units together for a few seconds will open the OFFSET function.
 - The keys serve to adjust the OFFSET of the various unit boilers.
 - The key confirms and passes to the next value
 - When the last unit has been confirmed, the function returns to the main menu
 - Pressing the key passes to the adjustment of the next value; any changes made will not be saved.
- OFFS. G1: Group 1 offset
OFFS. C1: Boiler 1 offset
OFFS. G2: Group 2 offset
OFFS. C2: Boiler 2 offset
OFFS. G3: Group 3 offset
OFFS. C3: Boiler 3 offset
OFFS. G4: Group 4 offset
OFFS. C4: Boiler 4 offset

CUP-WARMER PROGRAMMING (If installed on the machine)

- The display will read:

CUPWARMER PROG.

Pressing will open the submenu.

Single Cup Warmer

- The display will read:

CUPWARMER PROG.

- Pressing will cause the display to read, for example:

CUP-WARMER PROG. ON XX OFF xx

The message ON XX will begin to flash; use the keys to change the cup warmer open time (from 0 to 60 min.).

- Press to confirm and pass to the cup warmer OFF time (from 0 to 60 min.).

NOTE: Setting one of the two ON/OFF values to 0 will automatically bypass the function.

When the cup warmer is programmed, the button will flash slowly.

- Press the key to pass to the next page.

Single Temperature

- The display will read:

CUP-WARMER
SETPOINT xxx°C

- Using the keys, it is possible to increase or reduce the temperature within a certain range [40°C ÷ 80°C] / [104°F ÷ 176°F].
- Press to confirm and pass to the next step; the display will read.
- Press to return to the previous page without confirming.

Double Temperature

- The display will read:

CUP-WARMER ™
SETPOINT xx°C

- Using the keys, it is possible to increase or reduce the temperature no.1 within a certain range [40°C - 80°C] / [104°F - 176°F].
- Press to return to the previous page without confirming.
- Press to confirm and pass to the next step; the display will read:

CUP-WARMER j
SETPOINT xxx°C

- Using the keys, it is possible to increase or reduce the temperature no.2 within a certain range [40°C ÷ 80°C] / [104°F ÷ 176°F].
- Press to confirm and pass to the next step; the display will read:
- Press to return to the previous page without confirming.

DATE/TIME PROGRAMMING

- The display will read:

DATE/HOUR

- By pressing the key, the display will read for example:

MONDAY 08:22
08 MAY 2003

The times will start to flash on and off.

- Vary the hours and the minutes by using the keys.
- Confirm by pressing the key.

Once the hours and the minutes have been varied press again and vary the day, the month and the year by using the same procedure as described above.

On completion press to go on to the next page.

DISPLAY (AND DELIVERY TIME) SETTING (T3 version only)

On the main menu, it is possible to see the temperatures of the units on the machine. The temperatures are given in both in °C and °F. The first line shows the temperatures for units 1 and 3, while the second line shows the temperatures of units 2 and 4 or just the temperature for unit 2, if there are just 3 units on the machine. The function is opened by pressing the key and the display will read "TEMP. DISPLAY". Using the keys it is possible to select "ACTIVE" or "NOT ACTIVE". The and keys serve to confirm in the following cases:

- If "ACTIVE" is selected, this returns to the main menu.
- If "NOT ACTIVE" is selected, this opens the "DELIVERY TIME" function (described here below).
- The display will read:

DELIVERY TIME

- When the **ENTER** key is pressed, the display will read:

DELIVERY TIME
XXX

Using the keys, it is possible to select XXX as:

- NOT ACTIVE (pouring times will not be shown).
- ROW 1 (pouring times will be shown in row 1).
- ROW 2 (pouring times will be shown in row 2).
- Press **ENTER** to confirm and pass to the next step.
- Press **RESET** to return to the previous page without confirming.

If the delivery time display is on when a delivery is started - unless with the Continuous function - the bottom line of the display will show the delivery time (or times if more than one unit is delivering).

Each group has an area of the bottom line: the area on the left is for unit 1; the area alongside it is for unit 2 and so on, until the area on the far right, which is for unit 4.

The different areas are separated by vertical bars; if a group is not delivering, the area is empty.

Here below is an example: unit 1 is delivering (it has just started and 0 seconds have passed); unit 2 has been delivering for 12 seconds and unit 4 is delivering (it has been delivering for 21 seconds).

Area reserved to the delivery time of unit 2

Area reserved to the delivery time of unit 3

THURSDAY 12:00
0 | 12 | | 21

Area reserved to the delivery time of unit 1

Area reserved to the delivery time of unit 4

If the choice of activating the temperature display on the main page, when the power unit is switched on or the configuration menu closed, it is necessary to wait about a second before the temperatures are displayed. The available temperature information is as follows:

- One temperature: the current unit temperature;
- "LOW": the temperature of the unit is below 70°C;
- "N.C.": the temperature probe is not connected;
- "C.C.": the temperature probe has short circuited.

DELIVERY WHILE WASHING

It is possible to activate or not, the possibility to quit the menu with the **ENTER** key during a washing cycle to allow pouring.

When choosing to quit the washing function to be able to use the units not being washed for pouring as required, the washing cycle will be shown in the bottom or top line, depending on the choices made from the "POURING TIME" menu. If the pouring times are deactivated, the washing process will be viewed on the bottom line.

During an automatic washing cycle, off the menu (therefore, with pouring enabled), it is not

possible to enter the setting menu to switch off the machine either in manual or automatic mode.

The function is opened by pressing the **ENTER** key.

Using the keys, it is possible to select between the NOT ACTIVE / ACTIVE options.

The **ENTER** key serves to confirm and return to the main menu.

Pressing the **RESET** key returns to the main menu and any changes are not saved

PROGRAMMING THE POURING TIME (Digit version only)

The Aurelia Digit is equipped with an electronic system to control delivery times according to the coffee grinding fineness.

- The display will read:

DELIVERY TIME

- When the **ENTER** key is pressed, the display will read:

DELIVERY TIME
XXX

Using the keys, it is possible to select XXX as:

- NOT ACTIVE (pouring times will not be shown).
- ROW 1 (pouring times will be shown in row 1).
- ROW 2 (pouring times will be shown in row 2).
- Press **ENTER** to confirm and pass to the next step.

- Press **RESET** to return to the previous page without confirming.
If the delivery time display is on when a delivery is started - unless with the Continuous function - the bottom line of the display will show the delivery time (or times if more than one unit is delivering).

Each group has an area of the bottom line: the area on the left is for unit 1; the area alongside it is for unit 2 and so on, until the area on the far right, which is for unit 4.

The different areas are separated by vertical bars; if a group is not delivering, the area is empty.

Here below is an example: unit 1 is delivering (it has just started and 0 seconds have passed); unit 2 has been delivering for 12 seconds and unit 4 is delivering (it has been delivering for 21 seconds).

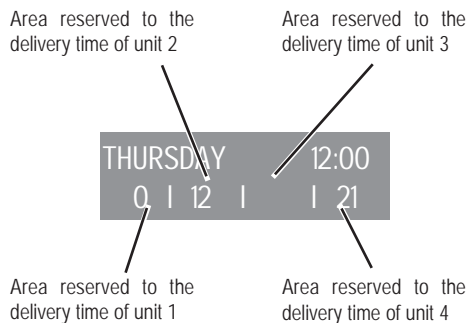

SETTING THE SET POINT PRESS:

The SETPOINT PRESS allows to chose the pressure/ temperature in the working status.

SETPOINT PRESS

When the **ENTER** key is pressed, the display will read:

SETPOINT PRESS
XX.XX BAR

Press **▼** **▲** to adjust the work-press/temp point.

- Press **ENTER** to confirm and pass to the next step.
- Press **RESET** to return to the previous page without confirming.

PRESSURE - TEMPERATURE TABLE AURELIA Digit

Bar	°C	°F
0,50	110,5	230,9
0,55	111,5	232,7
0,60	112,5	234,5
0,65	113,5	236,3
0,70	114	237,2
0,75	115	239
0,80	115,5	239,9
0,85	116,5	241,7
0,90	117,5	243,5
0,95	118	244,4
1,00	119	246,2
1,05	119,5	247,1
1,10	120,5	248,9
1,15	121	249,8
1,20	122	251,6
1,25	112,5	252,5
1,30	123	253,4
1,35	124	255,2
1,40	124,5	256,1
1,45	125	257
1,50	126	258,8
1,55	126,5	
1,60	127	

HISTORICAL ALARM VISUALISATION

- The display will read:

FAULTS HISTORY

- By pressing the **ENTER** key, the display will read:

ERROR 01

- Pressing the **▼** key, allows you to scroll down the ten previous alarms saved in the memory. After the tenth alarm, by pressing the **▼** key again you can go on to the next page.

MAINTENANCE PROGRAMMING

- The display will read:

MAINTENANCE

- By pressing the **ENTER** key, the display will read:

DELIVE. 10000
01 JANUARY 2005

- Use the **▼** **▲** keys to set both values.
- Use the **ENTER** key to confirm.
Once the set delivery limit or the set maintenance date have been reached, the display will visualize the message:

MAINTENANCE

To remove the MAINTENANCE message, move the date forward or increase the number of coffees.

WASHING ALARM

This is used to set the timer (hour and minutes) for the unit washing alarm.

The function can be accessed by pressing the **ENTER** key.

The **▼** **▲** keys can be used to select the ACTIVE and NOT ACTIVE options.

Using the **ENTER** key to select NOT ACTIVE will return to the main menu, while selecting ACTIVE means it is necessary to use the **▼** **▲** and **ENTER** keys to set the hour and minutes after which the alarm will be displayed. After the minutes have been set, the function returns to the main menu.

Pressing the **RESET** key returns to the main menu and any changes made are not saved.

SELECTING THE DESIRED LANGUAGE

- The display will read:

LANGUAGE

- Press the **ENTER** key to visualise the language already set. Choose the desired language by using the **▼** **▲** keys.
- Press **ENTER** to confirm and pass to the next step.
- Press **RESET** to return to the previous page without confirming.

TEMPERATURE UNITY MEASURE SELECTION

- The display reads:

TEMPERATURE

- Premendo il tasto **ENTER**, il display visualizza:

TEMPERATURE
FAHRENEIT

Or

TEMPERATURE
CELSIUS

- Press **▼** **▲** to modify the measures unit setted.
- Press **ENTER** to confirm and pass to the next step.
- Press **RESET** to return to the previous page without confirming.

KEYBOARD LIGHTING ADJUSTMENT

- The display reads:

LIGHT ADJUSTMENT

- By pressing **ENTER** key, the display will read:

KEYS X
DISPLAY Y

- With the “keys X” light blinking, select the value of desired brightness choosing from a minimum value of 1 to a maximum of 6 by using the **▼** **▲** keys.

- Confirm by pressing **ENTER**.
- The temperature “display Y” value blinks and with **▼** **▲** keys it is possible to set the display lighting “display Y” from a minimum value of 1 to a maximum of 3.

- Press **ENTER** to confirm and pass to the next step.
- Press **RESET** to return to the previous page without confirming.

SETTING THE TEMPERATURE POINT:

ENTER + **▲** press **ENTER** + **UP** to go directly to the Setting Point menu (this will be bars or °C/°F depend on the status view you were).

▼ **▲** press **UP** or **DOWN** to move up and down the working Point.

Press **ENTER** to confirm and pass to the next step.

MONITORING UNIT (°C/°F – BAR)

The display can also show you the pressure or temperature status of the boiler; to pass from one to the other, press the **▼** key on the display.

In the case of pressure, the reading will be shown in bar, while for temperature, it will be in degrees Celsius (°C) or Fahrenheit (°F). The display setting for the temperature can be chosen from the setpoint setting page. In fact, when choosing the temperature mode, the setpoint will be shown in degrees Celsius or Fahrenheit according to the chosen measurement.

ON OFF STAND-BY (ENERGY SAVING MODE)

This allows to rotate into the three working modes/statuses.

Press RESET for 3 sec to **switch on** → **off** → **stand-by** the machine status.

7.4 PROGRAMMING AURELIA V

DOSE PROGRAMMING

To access the programming units, proceed as follows:

NOTE: the procedure can be carried out with the machine on.

- To access the dose programming state of each unit press the first unit's continuous delivery key for 5 seconds.
- The delivery keys will begin to flash on and off.
- Access into the first unit's programming allows you to set the machine's function parameters.

COFFEE DOSE PROGRAMMING

To program the relative water doses for one of the delivery keys, proceed as follows:

- fill the filter-holder with the correct dose of coffee (the filter-holder can be single or double depending on the key you wish to program).
- Insert the filter-holder into the unit.
- Press one of the delivery buttons (see illustration):



- The delivery will start; once the desired amount has been reached, press the continuous key.
- The delivery will stop and the chosen dose key will turn off (the other keys will continue to flash).
- Press the continuous key to exit programming or to continue programming other dose keys.

NOTE: This procedure can be used on all units on the machine, as long as one unit is selected at a time, the others can continue to operate normally, except when the first unit is being programmed.

HOT WATER PROGRAMMING

- Enter the programming mode using the relevant procedure for the 1st unit on the right.
- Press the hot water selection key .
- Hot water delivery will start.
- Set the dose of hot water required and then press the hot water key again.
- Press the continuous key to exit the programming or to continue programming other selection keys.

Technician: To enable the pump while hot water is being dispensed, enter the programming mode for the first dispensing group then press the continual button for the second group.

- To change the settings, it is sufficient to press the hot water button ; if the button is not lit, the pump will not be enabled while hot water is being dispensed; if the button is lit while hot water is dispensed, the pump will be activated.
- Press the continual button for the second dispensing group to confirm the setting.

PROGRAMMING TIMED STEAM / LIQUID TEMPERATURE

- Enter the programming mode using the relevant procedure for the 1st unit on the left.
- Press the steam selection key .
- Steam ejection will start.
- Set the amount of steam required and press the steam selection key again.
- Press the continuous key to exit the programming or to continue programming other selection keys.
If the probe is fitted, the temperature at the end of delivery will be stored to memory.

AUTOMATIC CUP-WARMER PROGRAMMING (if present on the machine)

- Enter the programming mode using the relevant procedure for the 1st unit on the left.
- Press the cup-warming selection key .
- The delivery keys of the first and second unit will respectively signal the allotted automatic switching on and off times while the continuous keys of the first and second units will flash on and off.

As described in the chart, each delivery key

has an associated value, the starting up time of the cup-warmer is given by adding up the values of the first unit's lit-up keys.

The same counting method is used for the cup-warmer switching off time with the keys of the second unit.

Keys	1° GROUP (time ON)	2° GROUP (time OFF)
	2 minutes	5 minutes
	4 minutes	10 minutes
	8 minutes	20 minutes
	16 minutes	40 minutes

If at least one of the two times is null, the cup warmer will operate normally.

LEVELLING PUMP ACTIVATION

- Access the programming of the first group according to the relative procedure.
- Press the second unit continuous key (the key will light up).
- Press the second unit 1 small coffee key.

NOTE: If the 1 small coffee key is lit up, the pump will start up during the level.

If the 1 large coffee key is not lit up, the pump will not start up during the level.

- Press the second unit continuous key. In this way the selected pump setting is stored.
- To exit the programming, press the first unit continuous key.

NOTE: The settings will be saved even when exiting the first unit programming directly.

ADJUSTING KEYBOARD LIGHTING INTENSITY

- Access the programming of the first group according to the relative procedure.
- Press the second unit continuous del delivery key.
- The second unit 2 long coffees delivery key will flash on and off.
- Press the key more than once to vary the light intensity.

NOTE: You can set a maximum of five different degrees of light intensity.

- To store the set light intensity values in the memory, press the second unit continuous delivery key.
- To exit the programming, press the first unit continuous delivery key .

NOTE: The settings will be saved even when exiting the first unit programming directly.

STEAM NOZZLE WITH TEMPERATURE PROBE (OPTIONAL)





- Make sure the temperature probe is connected to the control unit.
- The temperature value can be planned by sampling or manually depending by the types of memorization planned in the parameter setting section and value goes from a minimum of 50°C to a maximum of 95°C.
- By pressing the key of the second group is possible to chose if you wont set the steam temperature value manually or by sampling.
- When you enter in this part of the menu, the key of the second group is switched on.
- By pressing the key of the second group, it is possible to change the way in which settings are stored to memory.
- Pressing the two short coffees key will change the memory storage mode.
- Press the continuous delivery key for the 2nd unit to memorise the temperature value input mode.



Sampling:

- After entering in the program of the first group, put a jag with milk under the steam wand and press the key, the delivery of steam will start.
- By pressing again the key, or if it is reached the maximum temperature, the control board memorizes the temperature reached. (If the temperature of the milk reaches the maximum level, steam delivery is stopped and the maximum value is set in the control unit).



Manually:





- After entering in the program of the first group, press the  keys of the first group, keys of the first and second group show the temperature starting from a minimum value of 50°C.
- At every key has an value:

Keys	1° GROUP	2° GROUP
	1 °C	10 °C
	2 °C	20 °C
	4 °C	-
	8 °C	-

- Sum together the value associated to the relevant lit key to a minimum value of 50°C to obtain the temperature setting.
- If the key is lit, it is necessary to add the reference value, while it is not required if the key is not lit.
- By pressing again the  key the value is planned and the machine came back to the general programming.
This way of setting doesn't use the delivery of steam.
- To escape from the program and save the setting, press the continuous  key of the first group.

Technician:







- In this steam temperature setting is possible to plan the offset value, from -15°C to +15°C, to obtain the correct temperature value.
- By pressing the  key of the first group, is showed the offset value setted: the way to show is the same of the way to show the final steam temperature.
- The keys of the first group show a value from 0 to 15°C, the  key of the second group show the offset sign:
- it is switched on the value is positive, if the key is switched off is negative.

Keys	1° GROUP	2° GROUP
	1 °C	+ 0 - °C
	2 °C	-
	4 °C	-
	8 °C	-

- By releasing the  key of the first group, you memorize the value and came back to the steam temperature setting.

STANDARD DOSE PROGRAMMING

- Setting predetermined values for the four doses of the first delivery unit is not possible. To do so, you must:
- Press the first unit continuous delivery  key and keep pressing it for at least 8 seconds, until the flashing delivery keys of the first unit turn off.
- The standard doses are illustrated in the following table:





					
40 cc	60 cc	50 cc	85 cc	9 sec.	0 sec.









NOTE: A time setting of 0 seconds for the steam will set it to operate continuously.

DOSE COPYING:

This procedure must be carried out for each unit individually by pressing the  continuous delivery key of the unit you desire to copy the doses onto and keep pressing it for at least 8 seconds, until the flashing delivery keys turn off.

AUTOMATIC CLEANING CYCLE

- To enter the automatic washing status, it is necessary to switch the machine off and then on again, while holding down the  hot water key and the  one long coffee, 1st unit during the initial Lamp test. At the end of the Lamp-test, the  hot water and the  one long coffee on all units will begin to flash on all units.

- Pressing the  one long coffee, will start the washing cycle for the relevant unit. After the washing cycle, it is possible to carry out a rinse cycle on the same group, by pressing the  key, one long coffee again.
- If you want make the rinsing cycle in an other time it's enough to switch off the machine: the control board memorizes the cleaning cycles that you must end.
- At the next switch on, in fact, the card will automatically enter the unit washing state without pressing the  and  one long coffee keys.
- Holding down the  key for 2 seconds will quit the washing state if there are no cycles to complete; otherwise the  one long coffee keys on the units still needing a rinse cycle.
- Holding down the  key for 2 seconds more will force quitting of the washing state, resetting the information about rinse cycles still to be completed.
- If the washing cycle is completed, the  one long coffee key for the unit will switch off and if there are no more rinse cycles to be completed, the card will quit the washing state.



7.5 PROGRAMMING AURELIA S

DOSE PROGRAMMING

In the Aurelia S version only the doses of water and timed steam can be programmed. To access the programming state you must:



- Hold down the  hot water key for five seconds.

HOT WATER

- Once in the programming state, pressing the  hot water key will activate hot water delivery; once at the required dose, press the  hot water key again and the control unit will memorise the set delivery time.

NOTE: Press the  key to quit the programming function.

TIMED STEAM

- Once in programming mode, pressing the  steam key will activate steam delivery; once at the required amount, press the  steam key again and the control unit will memorize the set delivery time.

NOTE: Press the  key to quit the programming function.



ADJUSTING LIGHTING INTENSITY KEYBOARD

- Access programming according to the relative procedure.
- Adjust the light intensity of the keys by pressing the first unit's 1 long coffee  key more than once.

NOTE: To exit programming press the  key.

PUMP ACTIVATION IN THE SELF-LEVELLING STAGE

- To set pump activation during the self-level stage, after first entering the programming mode, hold down the  key of the second unit.



The  key of the second unit will switch on and pressing the  key of the first unit will show the pump setting: if on, the pump will operate during levelling; if off, the pump will not operate during self-levelling.

Pressing the  key of the first unit, it is possible to change the setting for the pump during levelling.

NOTE: Press the  key to quit the programming function.













WATER DOSE AND STANDARD STEAM PROGRAMMING

- It is possible to enter preset values for steam and water. Proceed as follows:
- Press and hold down the  hot water key for at least 8 seconds, until the flashing keys switch off.
- The standard doses are shown in the table below:

	
9 sec.	0 sec.

NOTE: A time of 0 seconds for steam means it will function in continuous mode.

AUTOMATIC UNIT WASHING CYCLE

- To open the automatic washing cycle, first switch the machine off and then on again, holding down the  hot water and  coffee keys of the 1st unit during the initial Lamp-test. At the end of the Lamp-test, the  hot water and  one coffee keys on all units will start to flash on and off.
- Pressing the  one coffee key, the washing cycle will commence for the unit. At the end of the washing cycle, it is possible to rinse the same unit by pressing the  one coffee key.
- To carry out the rinse cycle later, switch off the machine and the card will maintain all washing cycles to be completed in its memory.
- When the machine is switched on again, the card will automatically enter the unit washing state without pressing the  and  one coffee keys.
- Holding down the  key for 2 seconds will exit the washing mode if there are no cycles to be completed; otherwise the  one coffee keys on the groups remaining to be rinsed will continue to flash.
- Holding down the  key for 2 seconds more will force the washing mode exit, resetting the information about the rinse cycles to be completed.
- If the washing cycle is completed, the  one coffee key of the unit will switch off; if there are no more rinse cycles to complete, the card will exit the washing mode.

8. CLEANING

8.1 SWITCHING OFF THE MACHINE

To switch the machine off press the main switch and set the machine to the O energy position.



Fig. 28

8.2 CLEANING THE OUTSIDE OF THE MACHINE

The machine must be set to "O" power (switch off and disconnecter open) before any cleaning operations are performed.



WARNING

It is not possible to clean the machine using water jets or standing it in water.



WARNING

Do not use solvents, chlorine-based products or abrasives.

Cleaning the work area: remove the worktop, lifting it up from the front and sliding it out. Remove the water collection dish underneath and clean everything with hot water and cleansers.

Cleaning the bottom: To clean all the chromium-plated areas, use a soft, damp cloth.

8.3 CLEANING THE STAINLESS COFFEE-HOLDERS

The stainless coffee-holders are situated under the delivery units, as shown in figure (29).



Fig. 29

NOTE: To clean proceed as follows:

- Turn the screw placed in the centre of the coffee-holder.
 - Slide the coffee-holder out and check that its holes are not obstructed but clean.
 - If obstructed, clean as described (Paragraph "CLEANING FILTERS AND FILTER-HOLDERS")
- We recommend cleaning the coffee-holder once a week.

8.4 CLEANING THE UNIT WITH THE AID OF THE BLIND FILTER

The machine is pre-set for cleaning the delivery unit with a specific washing powder.

The machine will initiate washing cycle which consists in the circulation of hot water followed by regular breaks.

We recommend carrying out a washing cycle at least once a day with special cleansers.



**CAUTION
RISK OF INTOXICATION**

Once the filter-holder has been removed, repeat delivery operations a few times to eliminate any cleanser residues.

To carry out the washing procedure, proceed as follows:

- 1) Substitute the filter with the delivery unit blind filter.
- 2) Fill it with two spoonfuls of special cleanser powder and insert it into the unit filter-holder.
- 3) Press one of the coffee keys and halt it after 10 seconds.
- 4) Repeat the procedure several times.
- 5) Remove the filter-holder and carry out a few deliveries.

8.5 CLEANING FILTERS AND FILTER-HOLDERS

Place two spoonfuls of special cleanser in half a litre of hot water and immerse filter and filter-holder (without its handle) in it leaving them to soak for at least half an hour. Then rinse abundantly with running water.

9. MAINTENANCE

NOTE: During maintenance/repairs, the parts used must be able to guarantee compliance with the safety and hygiene requirements envisaged for the device. Original replacement parts can offer this guarantee.

NOTE: After the repair or replacement of any components of parts that come into contact with food or water, it is necessary to carry out the washing procedure as described in point 1.4 or according to the manufacturer's instructions.

9.1 RESIN AND SOFTENER REGENERATION

To avoid scaling deposits in the boiler and in the heating exchangers, the softener must always be kept efficient.

Therefore, the ionic resins must be regularly regenerated.

Regeneration times are established according to the quantity of coffee delivered daily and the hardness of the water utilised.

As an indication, regeneration times can be calculated on the basis diagram illustrated in Fig. 30.

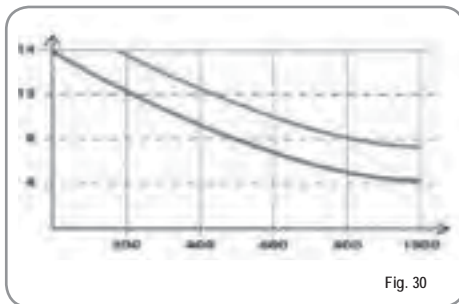

Fig. 30

Regeneration procedures are as follows:

- 1) Turn the machine off and place a container large enough to contain at least 5 litres under tube E (Fig. 31). Turn levers C and D from left to right; take the cap off by unscrewing knob and fill with 1 Kg normal kitchen salt (Fig. 32).

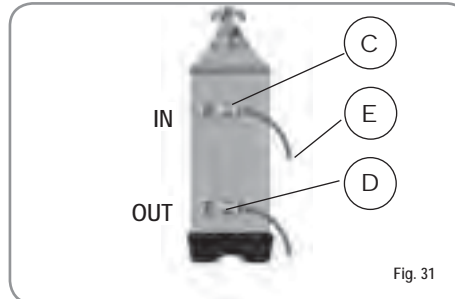

Fig. 31

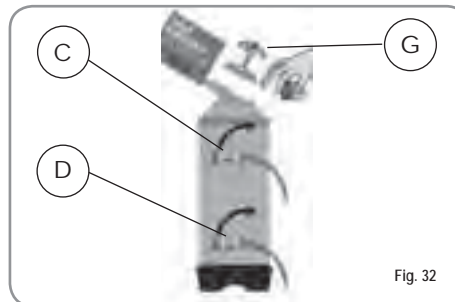

Fig. 32

- 2) Put the cap back on and reposition lever C moving it towards the left (Fig. 33) and allowing tube F to discharge the salty water until it has been eliminated and the water becomes fresh again (about half an hour).

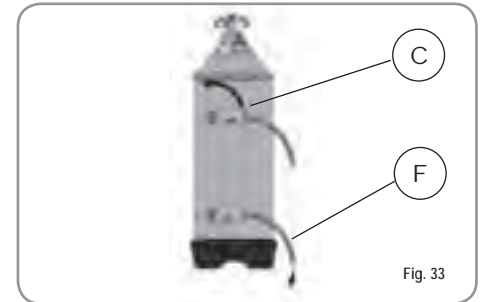

Fig. 33

- 3) Reposition lever D towards the left (Fig. 34).

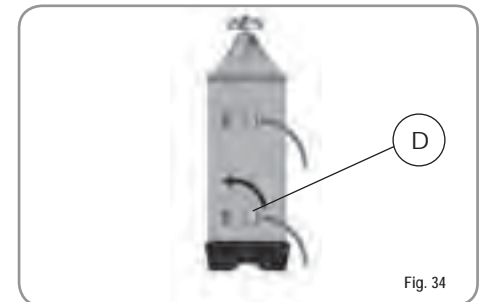







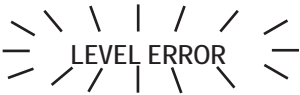
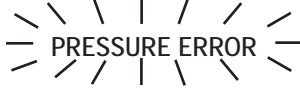









Fig. 34

10. Aurelia Digit MACHINE FUNCTION MESSAGES

DISPLAY AND KEY INDICATIONS	CAUSE	EFFECT	SOLUTION	NOTES
<p>DIAGNOSIS OF ERROR</p>	<p>At the time of the diagnosis the system presents faults within the control unit EPROM.</p>	<p>The machine will not heat and all its functions will be blocked.</p>		
<p>DELIVERY ERROR</p> 	<p>On reaching delivery time limit (120 seconds) the doser doesn't send out its set commands.</p>	<p>The display indicator and the 'continuous' key belonging to the relative unit will flash on and off.</p>	<p>Press the  key or one of the keys  .</p>	
<p>DOSER ERROR</p> 	<p>If the doser doesn't send out its set commands within the first three seconds from delivery onset.</p>	<p>If the delivery isn't manually halted, the maximum time limit (120 sec) will be blocked.</p>	<p>Press the  o uno dei tasti  .</p>	
<p>LEVEL ERROR</p> 	<p>If after 90 sec of machine functioning the water level is not re-established.</p>	<p>The display indicator will flash on and off. The pump is de-activated. The resistor and all the functions are halted.</p>	<p>Turn the machine off and then turn it on again. All its functions will be re-activated.</p>	
<p>PRESSURE ERROR</p> 	<p>When the machine's temperature is higher than 130°C.</p>	<p>The display indicator will flash on and off and the resistor is de-activated.</p>	<p>The system will be re-established as soon as the temperature goes below 130°C.</p>	<p>The boiler is provided with a manual refitting safety thermostat; if the resistor is not re-established, call a qualified technician.</p>

DISPLAY AND KEY INDICATIONS	CAUSE	EFFECT	SOLUTION	NOTES
	Incorrect electrical input caused by a malfunction in one of the machine charges.	The display reading will flash. The pump will switch off. The heating element and all other functions will be disabled.	Switch off the machine and send for a specialist technical engineer.	
FINE GRINDING	The machine registers values different from the set values.	A much longer delivery time.	Modify grinding degree and press the key  or one of the keys  .	By leaving the machine in the programming state, within 10 minutes from the last selection, the system will return to the previous configuration and the display will indicate its reestablishment of normal functioning.
COARSE GRINDING	The machine registers values different from the set values.	A much shorter delivery time.	Press the  key or one of the keys  .	

11. Aurelia V MACHINE FUNCTION MESSAGES

DISPLAY AND KEY INDICATIONS	CAUSE	EFFECT	SOLUTION	NOTES
	<p>If the doser doesn't send out its commands within three sec from the onset of delivery.</p>	<p>If the delivery is not halted manually, the time limit (120 sec.) will be blocked.</p>	<p>Interrupt the delivery.</p>	
	<p>If within 90 sec. from onset, with pump inserted during the levelling, at 180 sec., if the level has not been re-established.</p>	<p>The pump, the resistor and all the functions will be halted.</p>	<p>Turn the machine off for at least 5 sec. and then switch it on again.</p>	

ENGLISH

12. Aurelia S MACHINE FUNCTION MESSAGES

DISPLAY AND KEY INDICATIONS	CAUSE	EFFECT	SOLUTION	NOTES
	<p>If within 90 sec. from onset, with pump inserted during the levelling, at 180 sec., if the level has not been re-established.</p>	<p>The pump, the resistor and all the functions will be halted.</p>	<p>Turn the machine off for at least 5 sec. and then switch it on again.</p>	

IMPIANTO ELETTRICO / ELECTRIC SYSTEM / INSTALLATION ÉLECTRIQUE

Aurelia S

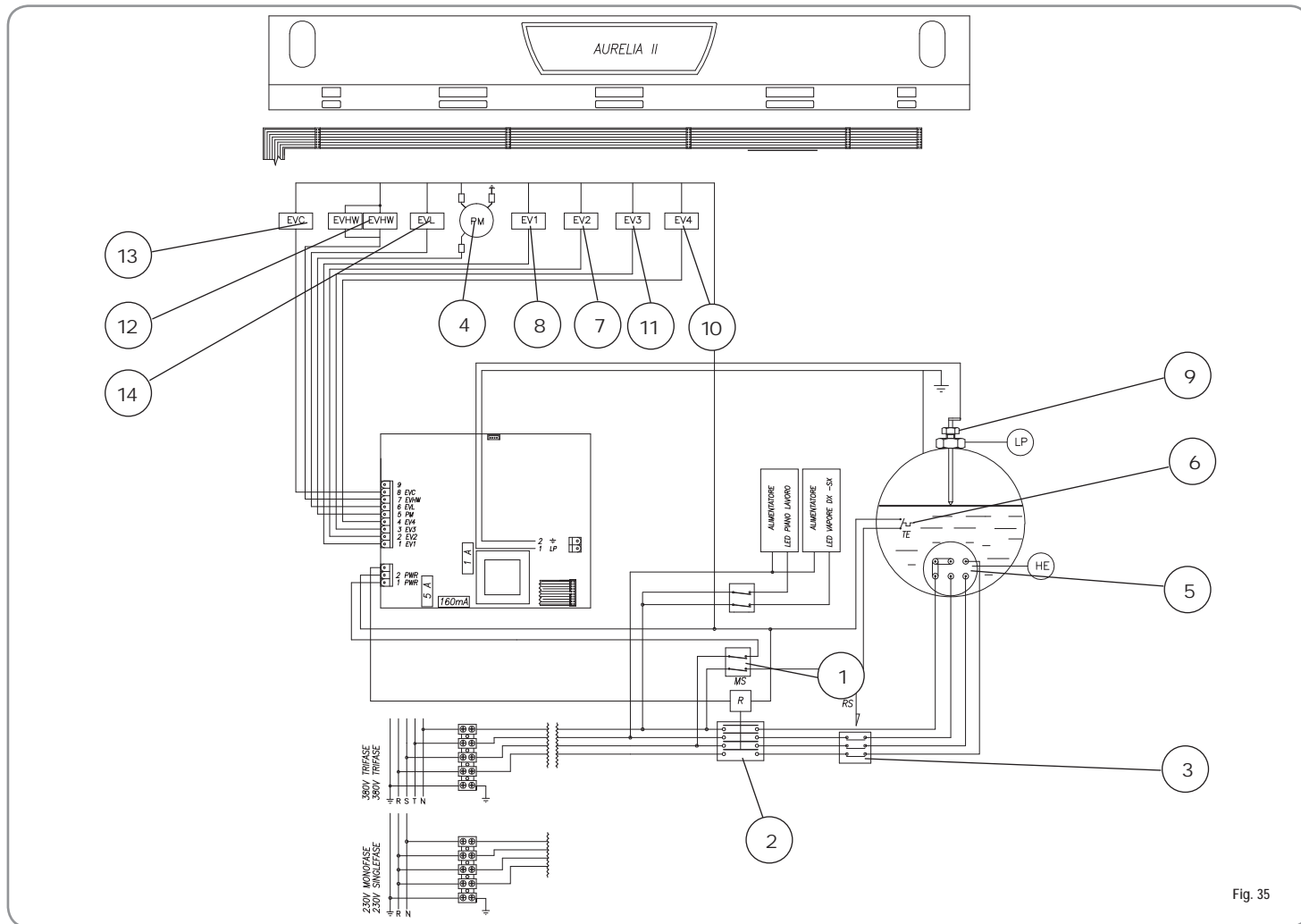

Fig. 35

LEGENDA / KEY

- | | | |
|--|---|--|
| <p>1 MS Interruttore / Main Switch.</p> <p>2 R Relè / Relay.</p> <p>3 RS Relè statico / Relay.</p> <p>4 PM Motore pompa / Pump Motor.</p> <p>5 HE Resistenza boiler / Heater ELEMENT.</p> <p>6 TE Termostato / Thermostat.</p> <p>7 EV2 Elettrovalvola gruppo 2 / Solenoid Valve unit 2.</p> | <p>8 EV1 Elettrovalvola gruppo 1 / Solenoid Valve unit 1.</p> <p>9 LP Sonda livello / level Probe.</p> <p>10 EV4 Elettrovalvola gruppo 4 / Solenoid Valve unit 4.</p> <p>11 EV 3 Elettrovalvola gruppo 3 / Solenoid Valve unit 3.</p> | <p>12 EVHW Elettrovalvola miscelatore / Solenoid Valve mixer.</p> <p>13 EVC Uscita scaldatasce / Cup-warmer output.</p> <p>14 EVL Elettrovalvola livello / Solenoid Valve level.</p> |
|--|---|--|

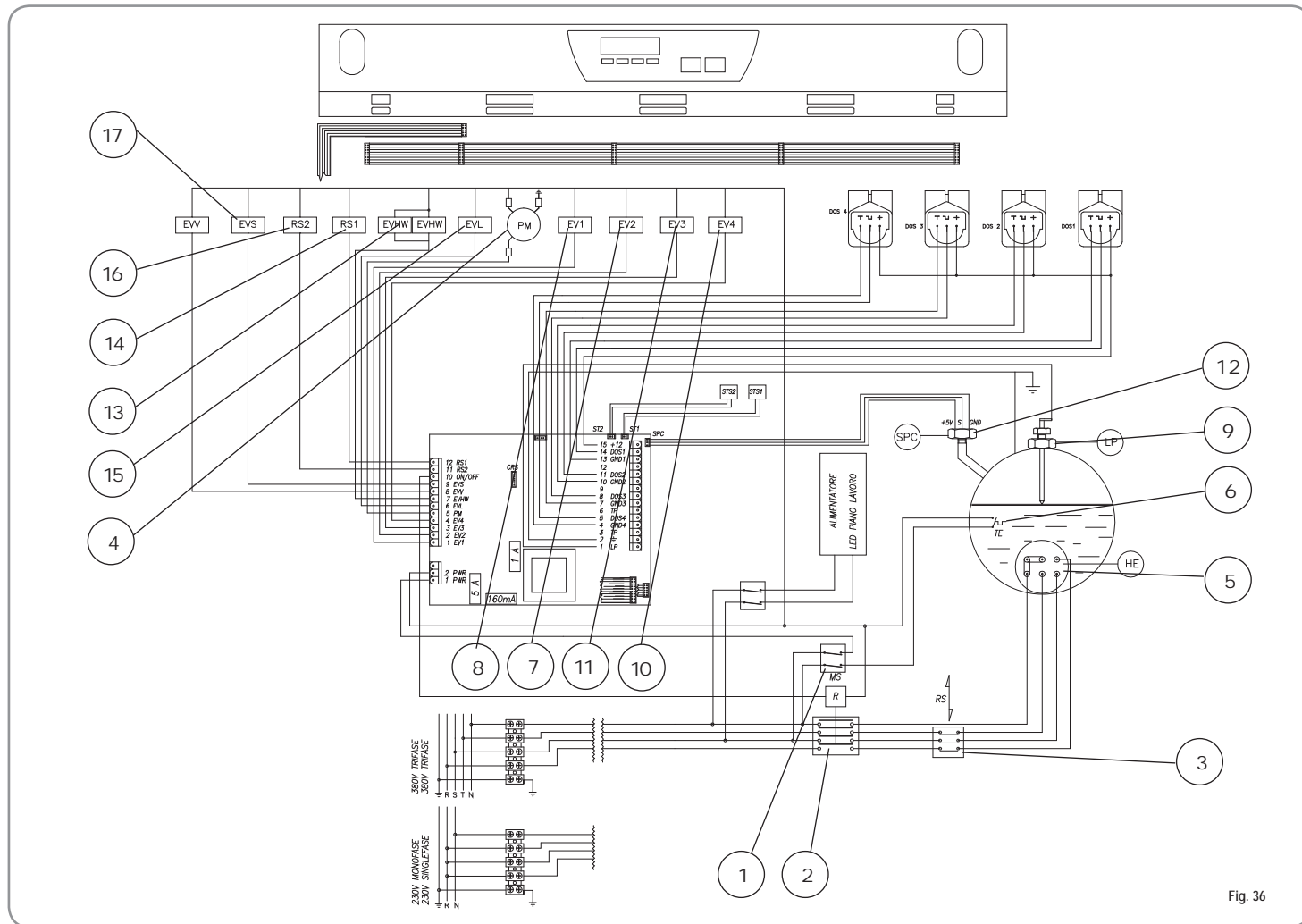

Fig. 36

LEGENDA / KEY

1 MS Interruttore / Main Switch.

2 R Relè / Relay.

3 RS Relè statico / Relay.

4 PM Motore pompa / Pump Motor.

5 HE Resistenza boiler / Heater ELEMENT.

6 TE Termostato / Thermostat.

7 EV2 Elettrovalvola gruppo 2 /
Solenoid Valve unit 2.

8 EV1 Elettrovalvola gruppo 1 /
Solenoid Valve unit 1.

9 LP Sonda livello / Level Probe.

10 EV4 Elettrovalvola gruppo 4 /
Solenoid Valve unit 4.

11 EV 3 Elettrovalvola gruppo 3 /
Solenoid Valve unit 3.

12 SPC Sensore pressione caldaia /
Solenoid Valve mixer.

14 RS1 Resistenza scaldacqua 1 /
Cupwarmer heating element 1

15 EVL Elettrovalvola livello /
Solenoid Valve level.

16 RS2 Resistenza scaldacqua 2 /
Cupwarmer heating element 2

17 EVS Elettrovalvola sfiato /
Vacuum electrovalve

IMPIANTO ELETTRICO / ELECTRIC SYSTEM / INSTALLATION ÉLECTRIQUE

Aurelia T3

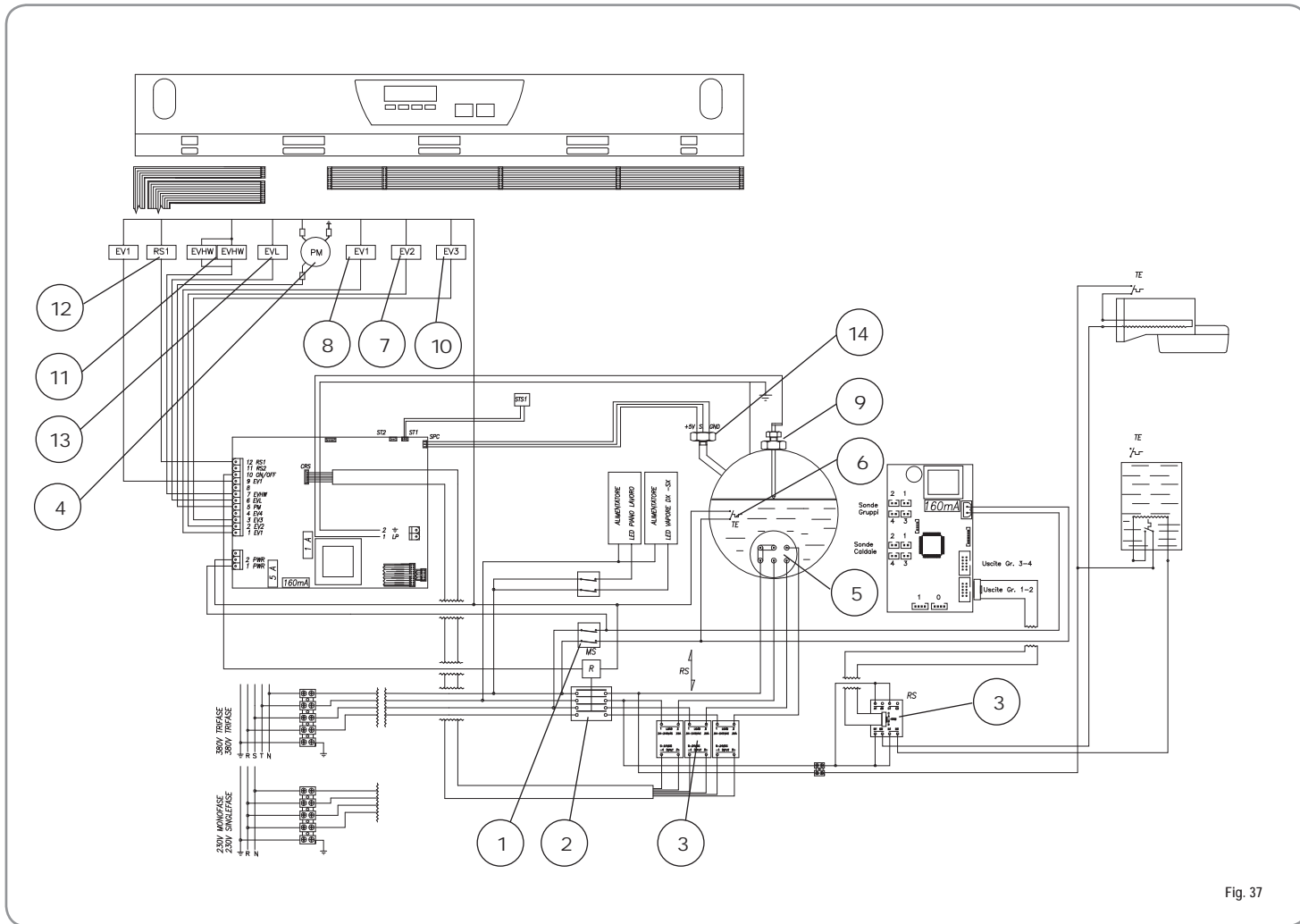

Fig. 37

LEGENDA / KEY

- | | | |
|--|--|--|
| <p>1 MS Interruttore / Main Switch.</p> <p>2 R Relè / Relay.</p> <p>3 RS Relè statico / Relay.</p> <p>4 PM Motore pompa / Pump Motor.</p> <p>5 HE Resistenza boiler / Heater ELEMENT.</p> <p>6 TE Termostato / Thermostat.</p> <p>7 EV2 Elettrovalvola gruppo 2 / Solenoid Valve unit 2.</p> | <p>8 EV1 Elettrovalvola gruppo 1 / Solenoid Valve unit 1.</p> <p>9 LP Sonda livello / Level Probe.</p> <p>10 EV 3 Elettrovalvola gruppo 3 / Solenoid Valve unit 3.</p> <p>11 EVHW Elettrovalvola miscelatore / Solenoid Valve mixer.</p> | <p>12 RS1 Resistenza scaldatazze 1 / Cupwarmer heating element 1</p> <p>13 EVL Elettrovalvola livello / Solenoid Valve level.</p> <p>14 SPC Snsore pressione caldaia</p> |
|--|--|--|

IMPIANTO ELETTRICO / ELECTRIC SYSTEM / INSTALLATION ÉLECTRIQUE

Aurelia V

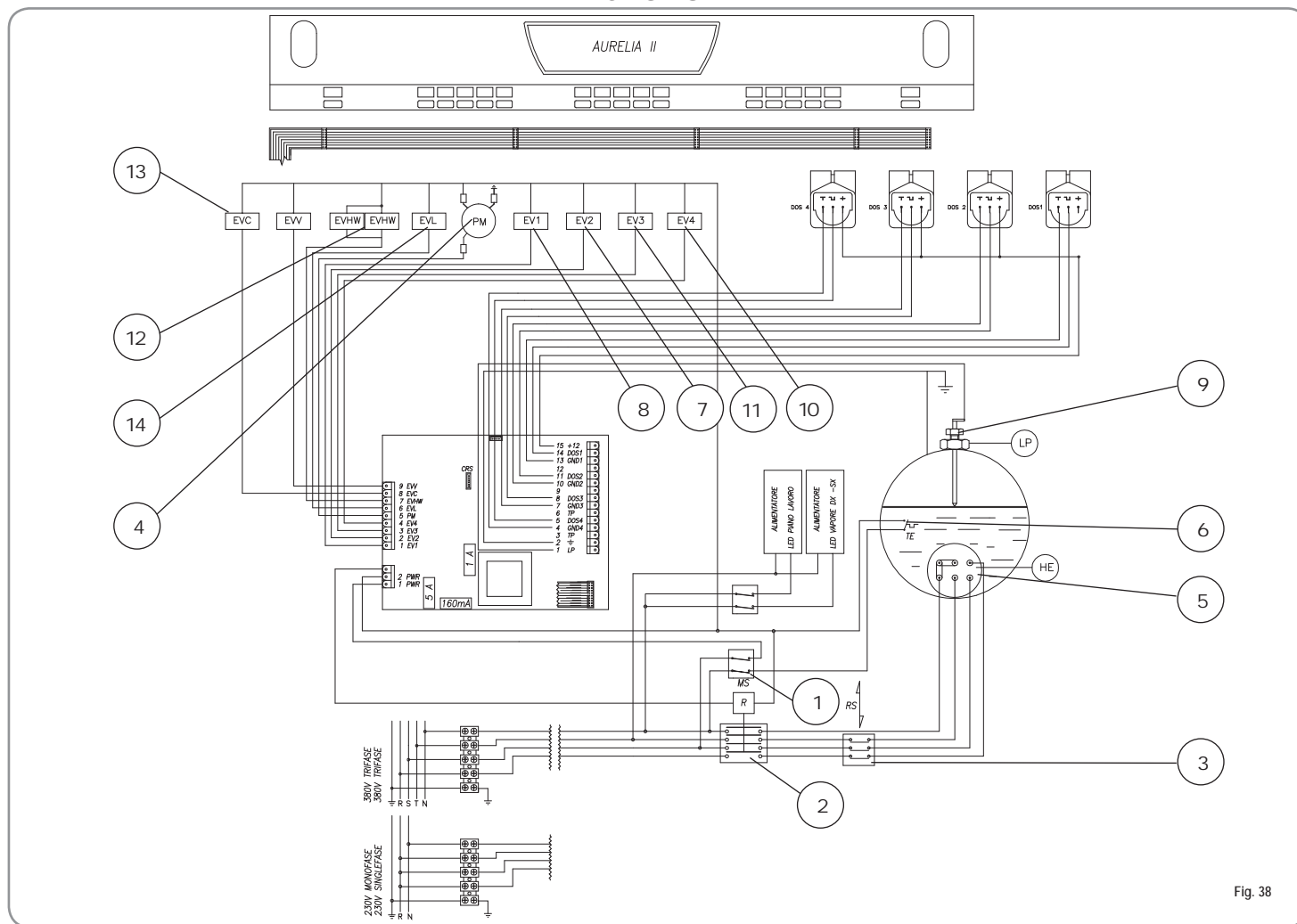

Fig. 38

LEGENDA / KEY

- | | | |
|--|--|--|
| <p>1 MS Interruttore / Main Switch.</p> <p>2 R Relè / Relay.</p> <p>3 RS Relè statico / Relay.</p> <p>4 PM Motore pompa / Pump Motor.</p> <p>5 HE Resistenza boiler / Heater ELEMENT.</p> <p>6 TE Termostato / Thermostat.</p> <p>7 EV2 Elettrovalvola gruppo 2 / Solenoid Valve unit 2.</p> | <p>8 EV1 Elettrovalvola gruppo 1 / Solenoid Valve unit 1.</p> <p>9 LP Sonda livello / Level Probe.</p> <p>10 EV4 Elettrovalvola gruppo 4 / Solenoid Valve unit 4.</p> <p>11 EV3 Elettrovalvola gruppo 3 / Solenoid Valve unit 3.</p> | <p>12 EVHW Elettrovalvola miscelatore / Solenoid Valve mixer.</p> <p>13 EVC Uscita scaldatazze / Cup-warmer output.</p> <p>14 EVL Elettrovalvola livello / Solenoid Valve level.</p> |
|--|--|--|



Nuova Distribution Centre
LLC 6940Salashan PKWY BLDG A 98248
Ferdale, WA
Tel. +1.360.3662226
Fax +1.3603664015
videoconf.+1.360.3188595
www.nuovasimonelli.it
info@nuovasimonelli.com



Via M. d'Antegiano, 6
62020 Belforte del Chienti
Macerata Italy
Tel. +39.0733.9501
Fax +39.0733-950242
www.nuovasimonelli.it
E-mail: n.simonelli@nuovasimonelli.it